

Type C-AL Aluminum Propeller Fans



Type C-AL

BELT DRIVE — 3,100 to 27,500 CFM
0" to 1/4" STATIC PRESSURE



Drive Mechanism

BELT DRIVE: Available in sizes from 24 inch to 54 inch. The Type C-AL belt driven fans are designed for quieter operation and lower initial cost. They use standardly available 1750 RPM motors.

VARIABLE PITCH PULLEYS: All models are equipped with a variable pitch motor pulley which allows fan speed adjustment where desirable. The settings made at the factory allow the fan to operate within the maximum safe capabilities of the motor. The pulley may be opened to reduce fan speed and thus decrease air flow.

If an increase in fan speed is desired, contact your American Coolair representative for information on fan performance and motor load before making any adjustment.

Motors

The American Coolair air-over-motor design provides extra capacity and economy because it serves to dissipate heat and thus increase horsepower capability.

Totally enclosed motors are standard. Several alternatives, such as explosion proof motors, energy efficient motors and severe duty motors, are available to fit your specific needs.

Only nationally recognized brand motors with nationwide service facilities are used.

Features

The C-AL fans utilize a cross-frame to support American Coolair's unique bearing and shaft assembly.

Power is applied directly to the fan/hub assembly in the same plane as the bearings. This reduces bearing load and dramatically increases fan bearing life. Bearings are permanently lubricated and sealed and have an L₁₀ life exceeding 300,000 hours.

Table of Contents

- **Application**..... 2
- **Type C-AL Fans-General Information**..... 2
- **C-AL Dimensional Data**..... 3
- **C-AL Performance**..... 3
- **Accessories and Installation** Back cover
- **Warranty and Caution**..... Back cover

Application

The Type C-AL fans are a general ventilation fan designed for efficiency and economy and built of corrosion resistant aluminum.

They are suggested for use in commercial and industrial applications including factories, warehouses, gymnasiums, underground parking garages or any areas requiring ventilation where side wall mounted fans are desirable and the corrosion resistance of aluminum construction is required.

Type C-AL fans are rugged and dependable. They are available in several sizes for a large selection of CFMs and pressures.

Construction

MATERIALS: The fan panel is fabricated of heavy-gauge aluminum and the uprights, which support the motor and propeller, are formed from heavy-gauge aluminum angle for maximum strength and rigidity. The six die-formed propeller blades are fabricated of heavy gauge aluminum that is rated excellent for corrosion resistance and fatigue strength.

METHODS: The entire panel assembly utilizes all-welded construction. A wide flared orifice is spun into the fan panel for improved performance.

Listings



UL705 – E39944

All Type C-AL ventilators are listed by Underwriters Laboratory, Inc. to U.S. and Canadian safety standards.

Certified ratings licensed by AMCA (Air Movement and Control Association International, Inc.), for both air and sound performance, are available for all Type C-AL fans. These, along with dimensional drawings are included in this form.

Additional Information Available

Octave band sound power levels are available for use by the acoustical engineer in predicting on-the-job sound levels.

American Coolair will provide installation instructions and maintenance information at your request as well as information on any air movement need you may have. Simply contact your nearest American Coolair representative.

American Coolair wishes to provide you with every assistance in determining your air movement requirements.

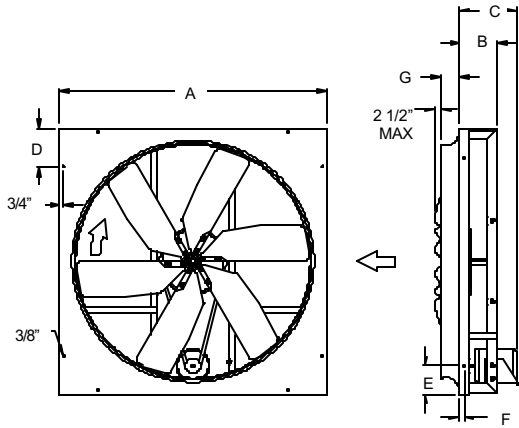

Dimensions

Dimension A is the O.D. of the square fan panel.

Dimension B is the depth from the face of the fan panel to the back of the fan frame.

Dimension C is the maximum width with constant speed, 3-phase TEFC motor of maximum horsepower for fan size and style indicated. This dimension will vary with the type and HP of the motor actually selected.

Dimension G is the spun orifice projection.

Performance Ratings



American Coolair Corporation certifies that the Type C-AL fan models shown herein are licensed to bear the AMCA seal. The ratings shown are based on tests and procedures performed in accordance with AMCA Publication 211 and AMCA Publication 311 and comply with the requirements of the AMCA Certified Ratings Program.

Fan Size	Dimensions in Inches							Metal Gauges	
	A	B	C	D	E	F	G	Panel	Blade
24	32	5 1/8	11 3/4	6	6	1 1/16	4	.080	.125
30	38	5 1/8	11 3/4	8	6	1 1/16	4	.080	.125
36	44	5 1/8	13 3/16	8	6	1 1/16	4	.080	.125
42	50	5 1/8	13 3/16	7	5	1 1/16	4	.080	.125
48	56	5 1/8	13 3/16	8	6	1 1/16	4	.080	.125
54	62	5 1/8	13 3/16	8	6	1 1/8	4	.125	.125

Item No.	Cubic Feet Per Minute (CFM) at Static Pressure ^{1,6}			Fan Model ²	Fan Size	Motor HP	Fan RPM	Sone Rating ³	Max BHP ^{4,6}	Approx. Ship Wt.	Shutter Model ⁵
	0"	1/8"	1/4"								
1	5,175	4,270	3,090	C-AL24G	24	1/4	650	13.8	0.31	60	S24
2	5,875	5,075	4,195	C-AL24H		1/3	738	17.9	0.42	62	S24
3	6,785	6,080	5,375	C-AL24J		1/2	852	22	0.60	67	S24
4	7,955	7,400	6,780	C-AL24K		3/4	999	31	0.92	79	S24
5	6,775	5,090	----	C-AL30G	30	1/4	471	10.1	0.31	64	S30
6	7,840	6,390	3,795	C-AL30H		1/3	545	13.3	0.42	68	S30
7	9,045	7,865	6,445	C-AL30J		1/2	629	17.7	0.60	73	S30
8	10,630	9,705	8,505	C-AL30K		3/4	739	24	0.92	90	S30
9	10,260	7,885	----	C-AL36H	36	1/3	422	11.2	0.42	85	S36
10	10,965	8,735	4,320	C-AL36J		1/2	451	13.0	0.60	94	S36
11	13,230	11,730	9,415	C-AL36K		3/4	544	18.1	0.92	100	S36
12	14,885	13,585	11,600	C-AL36L		1	612	22	1.26	102	S36
13	12,190	9,225	----	C-AL42H	42	1/3	347	10.0	0.42	95	S42
14	12,755	9,865	----	C-AL42J		1/2	363	10.9	0.60	104	S42
15	15,530	13,515	9,905	C-AL42K		3/4	442	15.9	0.92	109	S42
16	17,710	15,970	13,590	C-AL42L		1	504	20	1.26	111	S42
17	17,120	11,910	----	C-AL48J	48	1/2	302	11.7	0.60	124	S48
18	19,560	15,770	----	C-AL48K		3/4	345	15.5	0.92	129	S48
19	21,715	18,445	12,335	C-AL48L		1	383	18.4	1.26	131	S48
20	24,130	19,760	9,375	C-AL54L	54	1	349	18.3	1.26	238	S54
21	27,515	23,835	18,610	C-AL54M		1 1/2	398	23	1.77	252	S54

1 — Performance shown is for Installation Type A: free inlet, free outlet. Performance ratings do not include the effects of appurtenances in the airstream.

2 — The first three letters of the model number identify fan type and style. The next two numbers indicate fan size, the next letter identifies motor horsepower. Example: Model C-AL24G is Type "C", Style "AL", 24" size, 1/4 H.P.

3 — The sound ratings shown are loudness values in fan sones at 5 ft. (1.5m) in a hemispherical free field calculated per AMCA Standard 301. Values shown are for Installation Type A: free inlet fan sones levels. The sound ratings shown are at 0" static pressure.

4 — Maximum brake horsepower (BHP) within the catalog performance range. Power Ratings (BHP) do not include driveline losses. Bearing losses are included. BHP at most static pressures listed is less than that shown, in some cases substantially less. For specific BHP values at individual static pressure points contact your American Coolair representative. Because of the cooling the motor receives from the moving air stream, motor loading beyond the nominal nameplate ratings on these American Coolair fans does not overheat the motor and is within NEMA recommended limits and motor service factor. It is not detrimental to the motor and is economically desirable.

5 — Shutter models shown are automatic (gravity) type. Add suffix "M" for manual operation; suffix "E" for motor operation.

6 — To convert air performance (CFM and SP) and power (BHP) to metric units, multiply CFM x .000472 to obtain cubic meters per second (m³/s). Multiply SP x 248.36 to obtain pascals (Pa). Multiply BHP x .7457 to obtain kilowatts (kW).

Example: 3904 CFM x .000472 = 1.8427 m³/s
 0.125 SP x 248.36 = 31.05 Pa
 0.886 BHP x .7457 = 0.661 kW

ALL SPECIFICATIONS SUBJECT TO CHANGE WITHOUT NOTICE

Accessories

American Coolair provides a long list of accessories which can be selected from our Form No. 610-15. Fan ratings are determined without accessories. An allowance for the resistance of the shutter or other accessories is recommended. No precise figure can be stated as average since fan volume influences the amount of resistance the accessory causes. Accessories commonly used with Type C-AL fans include:

Wall Shutters: Companion wall shutters used with all Type C-AL fans are American Coolair designed and manufactured. American Coolair's Type S and SR sturdy, all aluminum weather-resistant shutters match the dimensions of the Type C-AL fan models and may be mounted to a common frame member. All sizes are available for automatic, manual or motorized use.

For improved fan performance and longer fan and shutter life, a space between the fan and shutter equal to 1/2 the diameter of the propeller is recommended. If job conditions will not permit this, a space of 5" to 7" depending on fan size should be minimum.

Fan Guards: American Coolair can provide, as optional accessories, basket type safety guards for both front (SGF) and motorside (SGM) for the Type C-AL fans. They are constructed of 16 gauge PVC coated wire with 1/2" x 1" spacing and shipped separately. They comply with OSHA regulations for fan blade guarding and are required for fans installed within 8 feet of floor or work area.

Wall Housing: All Type C-AL fans can be combined with our heavy gauge, galvanized steel or aluminum wall housings. This combination allows mounting on interior or exterior walls. This installation flexibility allows for uninterrupted interior space, for reversing the C-AL fans, and for necessary depth between fan blades and shutters. For detailed information regarding the use of this wall housing, refer to Form 610-15.

Spark Resistant Construction: For hazardous locations, any Type C-AL fan can be ordered with an explosion-proof motors. Motors only qualify for Class I Group D and Class II Group F and G hazards. (Type C-AL fans use aluminum blade assemblies as standard.)

Installation

Installation: American Coolair's Type C-AL fans may be mounted in any position. When used as exhaust fans, they are normally mounted with the face of the panel against the inside wall opening. When attaching the panel directly to the interior wall, the wall opening should be 3" less than the overall dimension of the fan frame. If the fan is to be recessed into the wall, the opening should be 1/4" larger than the fan frame dimension.

Shutters are mounted on the outside wall against the wall opening with a recommended distance between fan blades and shutter of 1/2 the blade diameter or a minimum distance of 5" to 7" depending on fan size.

Type C-AL fans are shipped in two packages, motor and drive pulley in one, and fan assembly, motor bracket and belt in another. Mounting, installation and maintenance instructions are included.

Before connecting the motor to electrical power source, check motor nameplate to be sure of correct phase and voltage.

Always check blade clearance and check direction of rotation with arrow on orifice before operating.

Supply Usage: When using Type C-AL fans as supply sources we do not recommend simply reversing the motor rotation. Type C-AL fans require the use of an American Coolair wall housing accessory. When fans are used as a supply source with shutters you must use manual or motorized shutters.

Motorized shutters require a 5" clearance behind shutters for motor and linkage, and should be ordered with a delay switch to delay fan operation until shutter is open. American Coolair's Type S shutter should not be used as a supply shutter when air velocity through the shutter exceeds 1,500 feet per minute or when it is required to open into a prevailing wind of more than 10 MPH.

Limited Warranty

In the sale of its products, American Coolair Corporation agrees to correct, by repairs or replacement, any defects in workmanship or material that may develop under proper and normal use during the period of one year from the date of shipment from the factory. Any product or part proving, upon American Coolair's examination, to be defective during limited warranty period will be repaired or replaced, at American Coolair's option, f.o.b. factory, without charge.

Deterioration or wear caused by chemicals, abrasive action or excessive heat shall not constitute defects.

Motors are guaranteed only to the extent of the manufacturer's warranty.

American Coolair's limited warranty does not apply to any of its products or parts that have been subject to accidental damage, misuse by the user, unauthorized modifications, improper installation or electrical wiring, or lack of proper lubrication or other service requirements as established by American Coolair.

Repairs or replacements provided under the above terms shall constitute fulfillment of all American Coolair's obligations with respect to limited warranty.

THE LIMITED WARRANTY STATED HEREIN IS IN LIEU OF ALL OTHER WARRANTIES, EXPRESS, STATUTORY OR IMPLIED, INCLUDING WITHOUT LIMITATION THAT OF MERCHANTABILITY AND FITNESS.

NO LIABILITY FOR REINSTALLATION COST OR FOR ANY SPECIAL, INDIRECT OR CONSEQUENTIAL DAMAGES OF ANY NATURE IS ASSUMED OR SHALL BE IMPOSED UPON AMERICAN COOLAIR.

WARNING

CAUTION



DO NOT INSTALL FAN WITH MOVING PARTS WITHIN 8 FEET OF FLOOR OR GRADE LEVEL WITHOUT A GUARD THAT COMPLIES WITH OSHA REGULATIONS. **DO NOT** USE UNLESS ELECTRICAL WIRING COMPLIES WITH ALL APPLICABLE CODES. **DO NOT** WIRE WITHOUT PROVIDING FOR A POWER SOURCE DISCONNECT AT THE FAN ITSELF. **DO NOT** SERVICE EXCEPT BY A QUALIFIED MAINTENANCE TECHNICIAN AND ONLY AFTER DISCONNECTING THE POWER SOURCE. FAILURE TO OBSERVE THESE PRECAUTIONS CAN RESULT IN SERIOUS INJURY OR DEATH.



REPRESENTED BY:

AMERICAN COOLAIR CORPORATION

P.O. BOX 2300 ~ Jacksonville, Florida 32203
Phone: (904) 389-3646
Fax: (904) 387-3449 or (904) 381-7560
E-mail: info@coolair.com