

Types RE & RES- Recirculating Roof Ventilators

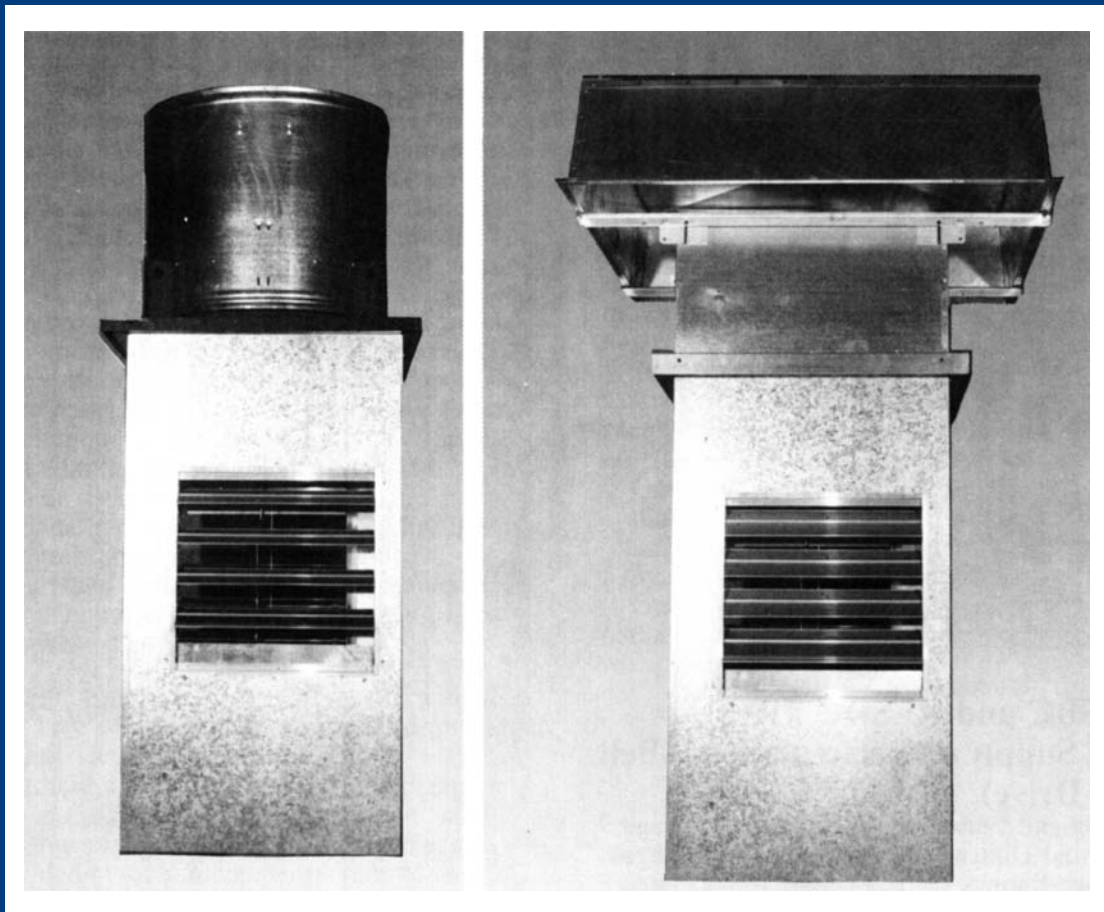

Contents

Type RE and RES PRVs—General Information Page 3

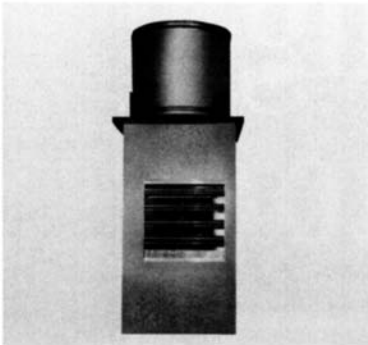

Type REBC and REDC PRVs (Exhaust or Recirculation—Belt or Direct Drive)

- Application and Features Page 4
- Drawings and Dimensions Page 4
- Performance Ratings Page 5
- Typical Specifications Page 5

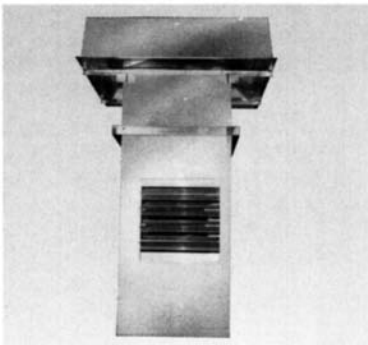

Type RESBC and RESDC PRVs (Exhaust, Supply or Recirculation—Belt or Direct Drive)

- Application and Features Page 7
- Drawings and Dimensions Page 8
- Performance Ratings Page 8
- Typical Specifications Page 8

Installation, Selection and Maintenance Page 10

Accessories Page 10

Special Performance Requirements Page 2

Warranty and Caution Back Cover

Special performance requirements

American Coolair makes axial, propeller and centrifugal type ventilation equipment to meet virtually any requirement.

Units built in larger sizes, smaller sizes and with performance capabilities other than the standard models listed are available. Custom modifications can also be supplied for unique applications.

If you do not find a standard model in this form that meets your needs, contact your American Coolair representative for further information.

American Coolair has over 70 years of experience in air moving systems and offers you the very best equipment and knowledgeable personnel.

Additional information available

Octave band sound power levels are available for use by the acoustical engineer in predicting on-the-job noise levels.

American Coolair will provide installation instructions and maintenance information at your request as well as information on any air movement need you may have. Simply contact your American Coolair representative.

American Coolair wishes to provide you with every assistance in determining your air movement requirements.

Type RE and RES PRVs

Application

Type RE and RES recirculators are multi-purpose power roof ventilators.

They are suggested for use in commercial and industrial applications where there is sufficient ceiling height to create a temperature differential between the floor and ceiling.

These applications include factories, warehouses and large commercial buildings.

Type RE and RES recirculators function as normal power roof ventilators in warmer weather and as an energy-saving recirculation system in cold weather.

Each unit is equipped with a reversible fan that redistributes warm ceiling air throughout the plant and reduces the building's heating requirement. With the flip of a switch, it can function as a conventional roof ventilator.

The Type RE is used for exhaust or recirculation.

The Type RES is used for exhaust, supply or recirculation.

Construction

MATERIALS: The fan/damper plenum is fabricated of galvanized steel on 24" through 48" models. An optional plenum construction protected by a finish coat of epoxy can be specified. This option is standard on 54" and 60" models. The fan panel is constructed of heavy-gauge steel and the uprights, which support the motor and propeller, are formed of heavy gauge steel angle for maximum strength and rigidity. Four high strength cast aluminum airfoil blades are securely attached to a heavy cast aluminum hub.

See individual types for information on shroud or hood materials and damper construction.

Painted parts are coated with epoxy to provide a protective coating rated excellent for hardness, impact resistance, adhesion and chemical resistance.

METHODS: American Coolair's Type RE and RES recirculating PRVs are especially constructed for rugged all-weather use. The fan panel utilizes all welded construction. Both the fan panel and dampers are mounted in the plenum which has removable flanges for ease of installation. An access panel is provided in the fan/damper plenum to aid routine maintenance and inspection. The reversible propeller incorporates specifically engineered airfoil sections and hub size for optimum efficiency and physical strength. Alternate adjustable pitch propeller blades are turned 180° to one another and a double orifice is attached to the fan panel.

All propellers are dynamically balanced.

Parts requiring painting are processed through the American Coolair five-stage pretreatment system prior to the application of any coatings to ensure maximum finish adhesion. These parts use a thermosetting epoxy powder paint with an average thickness of 3 mils and baked at 400 degrees Fahrenheit to a smooth, hard, continuous finish.

Drive mechanism

BELT DRIVE: Available in sizes 24 inch to 60 inch.

Belt driven models are designed for quieter operation and in many cases, lower initial cost. They use standardly available motors.

DIRECT DRIVE: Available in sizes 24 inch to 60 inch.

Direct driven models require less maintenance, offer longer operating life, increased efficiency and reduced operating cost.

VARIABLE PITCH PULLEYS: Most belt drive models are equipped with a variable pitch motor pulley which allows fan speed adjustment where desirable.

The setting made at the factory operates the fan at maximum safe load of the motor. See individual types for cautions concerning change of pulley setting.

Bearings

BELT DRIVE: Two heavy-duty, pillow-block ball bearings support the steel fan shaft.

DIRECT DRIVE: The propeller assembly is connected directly to the motor shaft. There are no fan bearings to require maintenance. Many motors are permanently lubricated.

Motors

American Coolair's air over motor design provides extra capacity and economy because air velocity over motor is used to dissipate heat and thus increase horsepower capability.

Totally enclosed motors are standard with American Coolair. Several alternatives are available to fit your specific needs, such as explosion proof motors, energy efficient motors and severe duty motors.

One-third HP to 5 HP single phase motors are available in 115v or 230v. One-third HP to 10 HP three phase motors are available in 208v, 230v, 460v or 575v.

Only nationally recognized brand motors with nationwide service facilities are used.

Type REBC and REDC

Exhaust or Recirculation—Belt or Direct Drive—4,500 to 48,000 CFM—to 1/2" static pressure

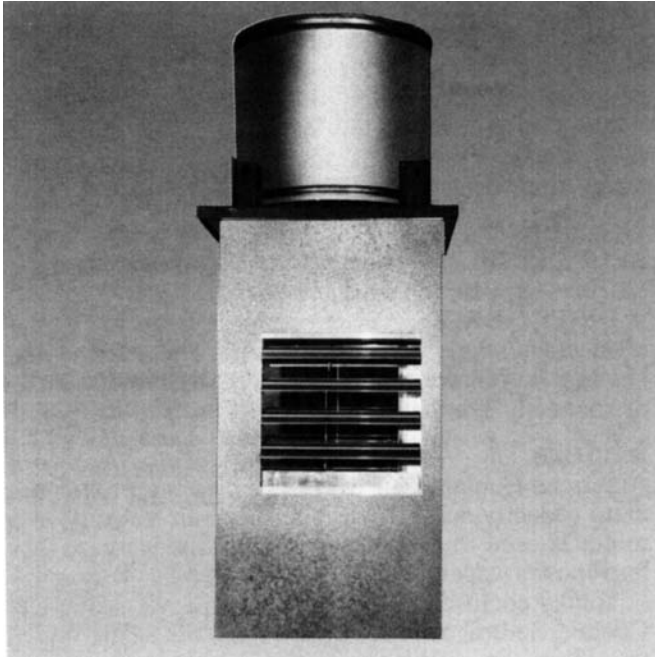

Application and features

REBC and REDC PRVs can either exhaust to the outside or recirculate inside building air.

The fan/damper plenum is suspended from a roof opening, and a stack cap and base are mounted to a curb above the opening on the roof.

The stack cap base is fabricated of heavy gauge steel. The wind shroud is made of galvanized steel; an exterior finish coat of epoxy can be specified. The stack cap dampers are fiberglass.

The fan/damper plenum construction is described on page 3.

Counter-balanced dampers fabricated of aluminum (the dampers have steel frames with aluminum blades on 24" models) are located in the sides of the plenum.

When the direction of airflow is up, the stack cap dampers are opened and the plenum dampers are closed creating an upblast exhaust PRV. When the direction of airflow is reversed, the stack cap dampers are closed and the plenum dampers open toward the interior of the plenum creating a recirculating unit.

For belt drive models, caution should be exercised in making changes in the variable pitch motor pulley setting. If pulley is opened to reduce propeller speed, air velocity may be reduced below minimum essential for all-weather usage. A speed increase may overload the motor. Contact your American Coolair representative for recommendation before making any speed adjustment.

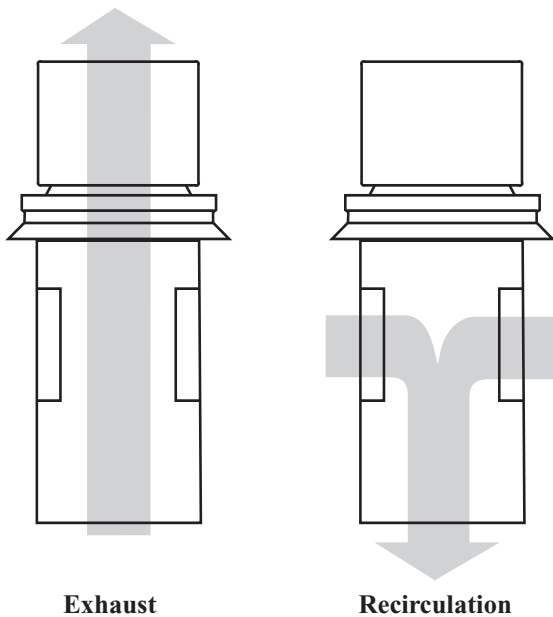

TYPE REBC-REDC

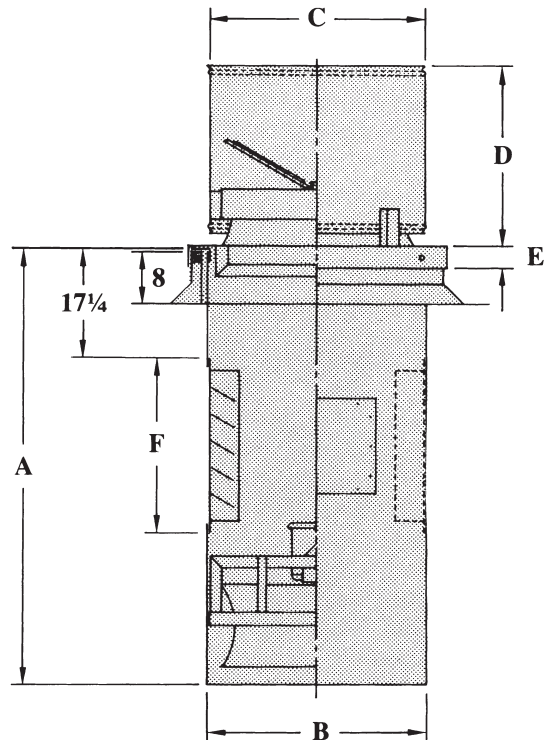

| BLADE DIA. | DIMENSIONS IN INCHES | | | | | |
|------------|----------------------|----|----|-----|---|-----|
| | A | B | C | D | E | F |
| 24 | 65½ | 33 | 32 | 28¾ | 2 | 25½ |
| 30 | 71½ | 39 | 38 | 33¾ | 2 | 31¾ |
| 36 | 77¾ | 45 | 44 | 33¾ | 2 | 37¾ |
| 42 | 83¾ | 51 | 50 | 38½ | 2 | 43¾ |
| 48 | 92¾ | 57 | 56 | 38½ | 2 | 49¾ |
| 54 | 98¾ | 63 | 62 | 43¾ | 3 | 55¾ |
| 60 | 104¾ | 70 | 68 | 46¾ | 3 | 61¾ |

Note: Roof curb dimensions are critical.
 Inside curb dimension—"B" dimension plus 1 inch
 Outside curb dimensions—"B" dimension plus 4 inches

Dimensions

Dimension "A" is overall height of plenum.

Dimension "B" is width of plenum (square).

Dimension "C" is diameter of circular wind shroud.

Dimension "D" is overall height above curb.

Dimension "E" is depth of curb cap flange.

Dimension "F" is overall length and width of damper including flange.

Performance

Ratings

American Coolair Corporation certifies that the Type RE PRV models shown herein have ratings based on tests to AMCA (Air Movement and Control Association Int'l, Inc.) Standard 210. Performance shown is for Type RE PRVs without ducts. For belt drive models, BHP does not include drive losses. BHP includes bearing losses. Performance shown is for exhaust operation. Performance for recirculation operation averages 5% less due to damper and plenum restrictions.

Typical Specifications

Recirculating power roof ventilators shall be Type RE as manufactured by American Coolair Corporation, Jacksonville, Florida; specific models shall be as shown in the fan schedule. Curb cap and fan component shall be of welded steel construction, PRV wind shroud shall be of galvanized steel. (Insert additional specifications from below for specific size PRV.) Shroud dampers shall be of fiberglass. Plenum dampers shall be of aluminum (for 24" models, plenum damper frames shall be of steel), with aluminum blades reinforced with galvanized steel. Fan blades shall be of high strength cast aluminum securely attached to a heavy cast aluminum hub. Propeller blade pitch shall be adjustable and blade shall be designed to move air equally in either direction, exhaust or recirculation. (For belt drive models: Ball bearings shall be of the heavy-duty

pillow-block type. Motor pulleys shall be variable pitch.) (For direct drive models: Entire propeller shall be mounted directly to motor shaft.) Performance ratings shall be based on tests in accordance with AMCA (Air Movement and Control Association Int'l, Inc.) standards and procedures. (Specify for each PRV model in the schedule: the required CFM and static pressure; motor enclosure, phase and volts; and accessories such as safety disconnect switch, safety guard, prefabricated curb and special protective coating.)

ADDITIONAL SPECIFICATIONS FOR 24" THROUGH 48" SIZE PRVs: Plenum shall be of galvanized steel.

ADDITIONAL SPECIFICATIONS FOR 54" AND 60" SIZE PRVs: Plenum shall be of hot rolled steel protected by a finish coat of epoxy.

| ITEM NO. | CUBIC FEET PER MINUTE (CFM) AT STATIC PRESSURE ¹ | | | | | PRV ² MODEL | FAN SIZE | MOTOR HP | FAN RPM | SONES ³ | BRAKE ⁴ HP | BLADE ⁵ PITCH | APPROX. SHIP WT. |
|----------|---|--------|--------|--------|--------|------------------------|----------|----------|---------|--------------------|-----------------------|--------------------------|------------------|
| | 0" | ¼" | ½" | ¾" | 1" | | | | | | | | |
| 1 | 5,450 | 4,450 | — | — | — | RE-C24H11 | | ½ | 1160 | 23 | .38 | 20° | 601 |
| 2 | 6,500 | 5,450 | — | — | — | RE-C24J11 | | ½ | 1160 | 26 | .55 | 27° | 603 |
| 3 | 6,550 | 5,950 | 5,300 | 4,600 | — | RE-C24K17 | 24 | ¾ | 1750 | 43 | .85 | 14° | 607 |
| 4 | 7,650 | 7,050 | 6,300 | 5,600 | 5,000 | RE-C24L17 | | 1 | 1750 | 48 | 1.13 | 18° | 612 |
| 5 | 9,300 | 8,750 | 8,150 | 7,300 | 6,200 | RE-C24M17 | | 1½ | 1750 | 53 | 1.66 | 25° | 616 |
| 6 | 8,350 | 6,950 | — | — | — | RE-C30J8 | | ½ | 870 | 21 | .56 | 22° | 710 |
| 7 | 8,800 | 7,700 | — | — | — | RE-C30K11 | | ¾ | 1160 | 33 | .81 | 15° | 714 |
| 8 | 10,500 | 9,450 | 8,200 | — | — | RE-C30L11 | | 1 | 1160 | 38 | 1.10 | 20° | 719 |
| 9 | 12,200 | 11,100 | 9,800 | 7,850 | — | RE-C30M11 | 30 | 1½ | 1160 | 38 | 1.65 | 25° | 723 |
| 10 | 12,250 | 11,500 | 10,750 | 10,000 | 9,100 | RE-C30N17 | | 2 | 1750 | 73 | 2.26 | 13° | 731 |
| 11 | 15,000 | 14,200 | 13,400 | 12,650 | 11,750 | RE-C30P17 | | 3 | 1750 | 79 | 3.30 | 18° | 748 |
| 12 | 19,100 | 18,300 | 17,500 | 16,650 | 15,750 | RE-C30Q17 | | 5 | 1750 | 85 | 5.50 | 27° | 763 |

Type REBC and REDC Performance Ratings (cont'd)

| ITEM NO. | CUBIC FEET PER MINUTE (CFM) AT STATIC PRESSURE ¹ | | | | | PRV ² MODEL | FAN SIZE | MOTOR HP | FAN RPM | SONES ³ | BRAKE ^{4,6} HP | BLADE ⁵ PITCH | APPROX. SHIP WT. |
|----------|---|--------|--------|--------|--------|------------------------|----------|----------|---------|--------------------|-------------------------|--------------------------|------------------|
| | 0" | 1/8" | 1/4" | 3/8" | 1/2" | | | | | | | | |
| 13 | 8,800 | 7,400 | — | — | — | RE-C36J8 | | 1/2 | 870 | 26 | .56 | 10° | 887 |
| 14 | 11,400 | 9,700 | 7,300 | — | — | RE-C36K8 | | 3/4 | 870 | 27 | .82 | 15° | 891 |
| 15 | 13,600 | 11,850 | 9,600 | — | — | RE-C36L8 | | 1 | 870 | 28 | 1.11 | 20° | 897 |
| 16 | 15,200 | 13,400 | 11,200 | — | — | RE-C36M8 | | 1 1/2 | 870 | 30 | 1.67 | 24° | 901 |
| 17 | 16,100 | 14,850 | 13,500 | 11,900 | — | RE-C36N11 | 36 | 2 | 1160 | 44 | 2.21 | 16 1/2° | 908 |
| 18 | 20,500 | 19,100 | 17,700 | 16,100 | 14,750 | RE-C36P11 | | 3 | 1160 | 48 | 3.26 | 24° | 927 |
| 19 | 22,700 | 22,000 | 21,300 | 20,500 | 19,500 | RE-C36Q17 | | 5 | 1750 | 98 | 5.60 | 15° | 941 |
| 20 | 27,400 | 26,600 | 26,000 | 25,100 | 24,100 | RE-C36R17 | | 7 1/2 | 1750 | 91 | 8.21 | 20° | 982 |
| 21 | 32,400 | 31,750 | 31,000 | 30,000 | 28,500 | RE-C36S17 | | 10 | 1750 | 109 | 11.05 | 25 1/2° | 1010 |
| 22 | 14,000 | 12,200 | — | — | — | RE-C42L8 | | 1 | 870 | 26 | 1.11 | 10° | 1145 |
| 23 | 17,250 | 15,150 | 12,600 | — | — | RE-C42M8 | | 1 1/2 | 870 | 30 | 1.67 | 14° | 1149 |
| 24 | 19,550 | 17,500 | 15,000 | 12,000 | — | RE-C42N8 | 42 | 2 | 870 | 33 | 2.24 | 17° | 1173 |
| 25 | 26,000 | 24,200 | 22,100 | 19,000 | 13,500 | RE-C42P8 | | 3 | 870 | 36 | 3.32 | 26° | 1192 |
| 26 | 28,800 | 27,500 | 26,150 | 24,500 | 22,600 | RE-C42Q11 | | 5 | 1160 | 55 | 5.54 | 20° | 1211 |
| 27 | 21,550 | 18,600 | — | — | — | RE-C48M6 | | 1 1/2 | 680 | 26 | 1.66 | 15 1/2° | 1454 |
| 28 | 25,200 | 22,500 | 18,800 | — | — | RE-C48N6 | | 2 | 680 | 28 | 2.22 | 20° | 1475 |
| 29 | 30,100 | 27,200 | 23,400 | — | — | RE-C48P6 | | 3 | 680 | 31 | 3.22 | 27° | 1673 |
| 30 | 21,000 | 18,600 | 16,000 | — | — | RE-C48N8 | 48 | 2 | 870 | 35 | 2.21 | 10° | 1449 |
| 31 | 25,800 | 23,600 | 21,100 | 18,100 | — | RE-C48P8 | | 3 | 870 | 40 | 3.30 | 14° | 1466 |
| 32 | 35,400 | 33,200 | 30,750 | 28,000 | 24,250 | RE-C48Q8 | | 5 | 870 | 45 | 5.42 | 23° | 1631 |
| 33 | 37,400 | 36,400 | 35,000 | 33,400 | 30,500 | RE-C48R11 | | 7 1/2 | 1160 | 68 | 8.40 | 16 1/2° | 1637 |
| 34 | 44,500 | 43,000 | 41,000 | 39,000 | 36,850 | RE-C48S11 | | 10 | 1160 | 77 | 11.10 | 21° | 1673 |
| 35 | 23,100 | 20,400 | — | — | — | RE-C54N6 | | 2 | 680 | 36 | 2.09 | 10° | 1931 |
| 36 | 30,100 | 27,000 | 23,100 | — | — | RE-C54P6 | | 3 | 680 | 39 | 3.31 | 15° | 2128 |
| 37 | 39,500 | 37,000 | 32,500 | 28,000 | — | RE-C54Q6 | | 5 | 680 | 47 | 5.46 | 23° | 1631 |
| 38 | 35,800 | 33,600 | 31,100 | 28,150 | 24,250 | RE-C54Q8 | 54 | 5 | 870 | 57 | 5.43 | 13 1/2° | 2086 |
| 39 | 45,900 | 43,200 | 40,750 | 38,000 | 34,600 | RE-C54R8 | | 7 1/2 | 870 | 66 | 8.31 | 20° | 2122 |
| 40 | 46,700 | 45,100 | 43,500 | 41,600 | 39,600 | RE-C54S11 | | 10 | 1160 | 104 | 11.16 | 13° | 2128 |
| 41 | 32,000 | 28,500 | 24,100 | — | — | RE-C60P6 | | 3 | 680 | 44 | 3.28 | 10° | 2444 |
| 42 | 42,750 | 39,500 | 35,400 | 30,500 | — | RE-C60Q6 | | 5 | 680 | 48 | 5.56 | 16° | 2613 |
| 43 | 36,100 | 33,100 | 30,100 | 26,500 | — | RE-C60Q8 | 60 | 5 | 870 | 63 | 5.55 | 8° | 2402 |
| 44 | 48,000 | 45,400 | 42,600 | 39,500 | 35,600 | RE-C60R8 | | 7 1/2 | 870 | 77 | 8.38 | 13° | 2438 |

1—Performance shown is for exhaust operation. CFM performance for recirculation operation will be 1½% to 8% less, depending on size and CFM of fan, due to recirculation and damper restriction.

2—The first four letters of the model number identify **fan type, drive configuration and style**. (Drive configuration has been omitted in table. Insert “D” for direct drive or “B” for belt drive to complete model number.) The next two numbers indicate **fan size**; the next letter identifies motor **horsepower**; the last number (or numbers) indicates **RPM** in hundreds. Example: Model REDC24H11 is a Type RE, direct drive. Style C, 24” size, 1/2 HP, 1160 RPM.

3—The sound ratings shown are loudness values in fan sones at 5 ft. (1.5m) in a hemispherical free field calculated per AMCA Standard 301. Values shown are for Installation Type A: free inlet fan sone levels. The sound ratings shown are at 0” static pressure.

4—Maximum brake horsepower (BHP) within the catalog performance range. On belt drive models, BHP does not include drive losses. Bearing losses are included. BHP at most static pressures listed is less than that shown, in some cases substantially less. For specific BHP values at individual static pressure points contact your American Coolair representative. Because of the cooling the motor receives from the moving air stream, motor loading beyond the nominal nameplate rating on these American Coolair fans does not overheat the motor and is within NEMA recommended limits and motor service factor. It is not detrimental to the motor and is economically desirable.

5—All models use a four bladed adjustable pitch propeller with cast aluminum airfoil blades. Alternate blades are pitched 180° apart. Blade pitch in degrees from plane of hub is shown.

6—To convert air performance (CFM and SP) and power (BHP) to metric units, multiply CFM x .000472 to obtain cubic meters per second. Multiply SP x 248.36 to obtain Pa (Pascals). Multiply BHP x .7457 to obtain Kilowatts.

Example: 3904 CFM x .000472 = 1.8427 Cubic meters per second.
0.125 SP x 248.36 = 31.05 Pascals
0.886 BHP x .7457 = 0.661 Kilowatts

Type RESBC and RESDC

Exhaust, Supply or Recirculation—Belt or Direct Drive-2,600 to 40,000 CFM—to 1/2" static pressure

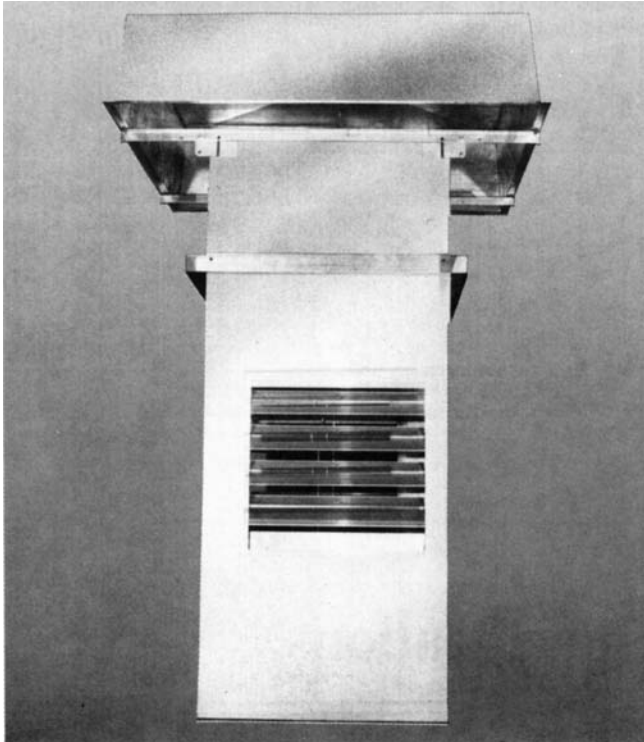

Application and features

RESBC and RESDC PRVs can exhaust to the outside, supply from the outside or recirculate inside building air.

With the addition of an optional modulating damper motor, various amounts of outside air may be mixed with recirculated inside building air.

The fan/damper plenum is suspended from a roof opening, and a hood and base are mounted to a curb above the opening on the roof.

The hood and base are made of galvanized steel. An exterior finish coat of epoxy can be specified.

The fan/damper plenum construction is described on page 3.

Motor operated, center pivoted dampers are located in the sides of the plenum and at the top of the plenum in the throat of the roof curb. Dampers are linked together so that as the throat damper closes, the plenum dampers open and vice versa. All dampers are shipped installed in the plenum.

When the direction of airflow is up, the dampers in the sides of the plenum are closed and the damper at the top of the plenum is opened creating an exhaust PRV. When the direction of airflow is reversed and the damper arrangement is not changed, the unit acts as a supply PRV. With the direction of airflow down and the damper positions reversed, a recirculating unit is created.

For belt-drive models, caution should be exercised in making changes in the variable pitch motor pulley setting. The motor pulley can be opened to reduce fan speed and thus decrease air flow.

If an increase in fan speed is desired, contact your American Coolair representative for information on fan performance and motor load before making any adjustment.

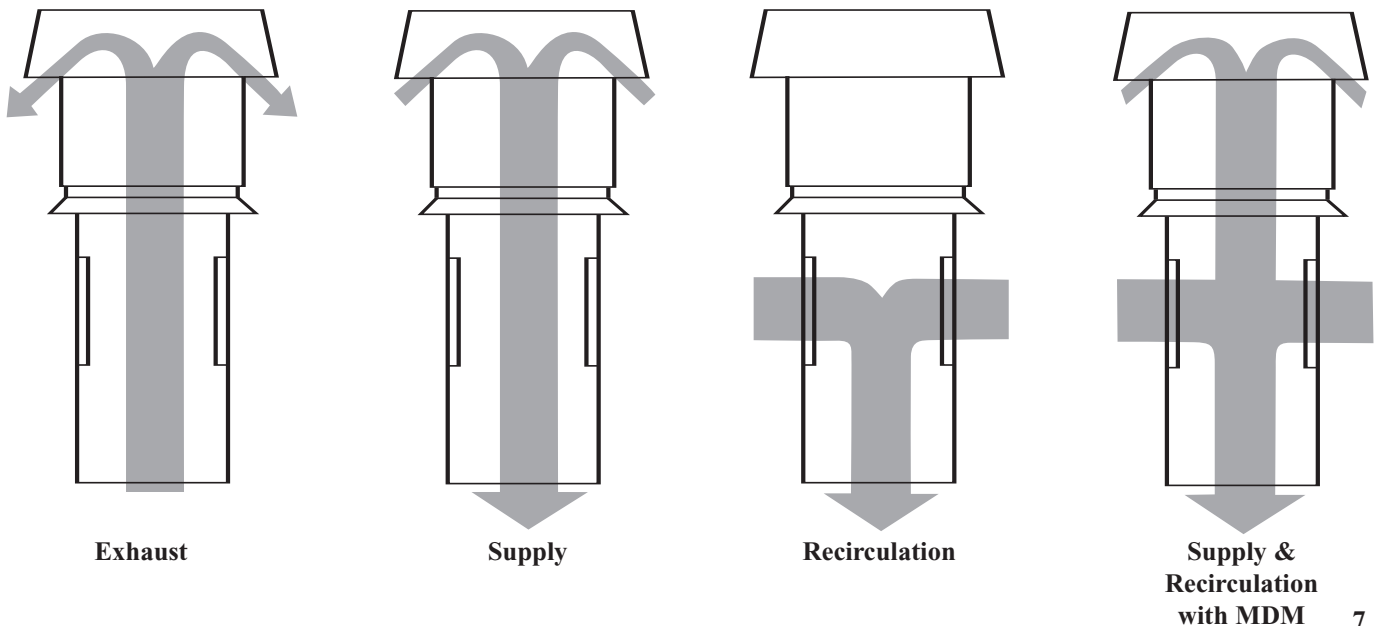

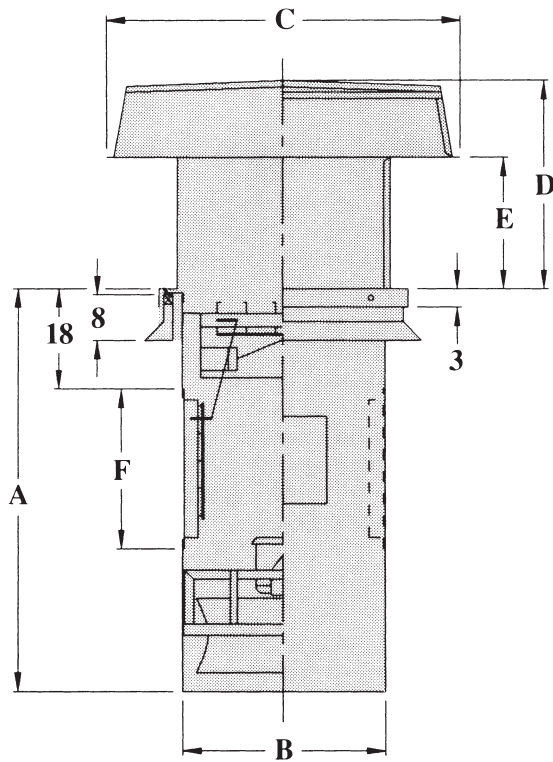

TYPE RESBC-RESDC

Dimensions

Dimension "A" is overall height of plenum.

Dimension "B" is width of plenum (square).

Dimension "C" is OD of square hood.

Dimension "D" is overall height above curb.

Dimension "E" is distance from curb to hood.

Dimension "F" is overall length and width of damper, including flange.

DIMENSIONS IN INCHES

| BLADE DIA. | A | B | C | D | E | F |
|------------|------|----|-----|-----|-----|-----|
| 24 | 65½ | 33 | 57 | 33¾ | 20¾ | 25 |
| 30 | 71¾ | 39 | 67 | 38½ | 20¾ | 30½ |
| 36 | 77¾ | 45 | 78 | 41¾ | 20¾ | 36½ |
| 42 | 83¾ | 51 | 88 | 43¾ | 20¾ | 42½ |
| 48 | 92¾ | 57 | 98 | 51 | 23¾ | 48½ |
| 54 | 98¾ | 63 | 109 | 55¾ | 23¾ | 54½ |
| 60 | 104¾ | 70 | 109 | 55¾ | 23¾ | 60½ |

Note: Roof curb dimensions are critical.

Inside curb dimension—"B" dimension plus 1 inch

Outside curb dimensions—"B" dimension plus 4 inches

Performance Ratings

American Coolair Corporation certifies that the Type RES PRV models shown herein have ratings based on tests to AMCA (Air Movement and Control Association Int'l, Inc.) Standard 210. Performance shown is for Type RES PRVs without ducts. For belt drive models, BHP does not include drive losses. BHP includes bearing losses. Performance shown is for supply or recirculation operation. Performance for exhaust operation will be slightly less due to hood restriction.

Recirculating power roof ventilators shall be Type RES as manufactured by American Coolair Corporation, Jacksonville, Florida; specific models shall be as shown in the fan schedule. Fan component shall be of welded steel construction, PRV hood and base shall be of galvanized steel. (Insert additional specifications from below for specific size PRV.) PRV throat damper and plenum dampers shall be centered pivoted and motor operated and shall be of aluminum. Fan blades shall be of high strength cast aluminum securely attached to a heavy cast aluminum hub. Propeller blade pitch shall be adjustable and blade shall be designed to move air equally in either direction, exhaust or supply/recirculation. (For belt drive models: Ball bearings shall be of the heavy-duty pillow-block type. Motor pulleys shall be variable pitch.) (For

direct drive models: Entire propeller assembly shall be mounted directly to motor shaft.) Performance ratings shall be based on tests in accordance with AMCA (Air Movement and Control Association Int'l, Inc.) standards and procedures. (Specify for each PRV model in the schedule the required CFM and static pressure; motor enclosure, phase and volts; and accessories such as modulating damper motor, safety disconnect switch, safety guard, prefabricated curb and special protective coating.)

ADDITIONAL SPECIFICATIONS FOR 24" THROUGH 48" SIZE PRVs: Plenum shall be of galvanized steel.

ADDITIONAL SPECIFICATIONS FOR 54" AND 60" SIZE PRVs: Plenum shall be of hot rolled steel protected by a finish coat of epoxy.

Type RESBC and RESDC

| ITEM NO. | CUBIC FEET PER MINUTE (CFM) AT STATIC PRESSURE ¹ | | | | | PRV ² MODEL | FAN SIZE | MOTOR HP | FAN RPM | SONES ³ | BRAKE ^{4,6} HP | BLADE ⁵ PITCH | APPROX. SHIP WT. |
|----------|---|--------|--------|--------|--------|------------------------|----------|----------|---------|--------------------|-------------------------|--------------------------|------------------|
| | 0" | ¼" | ½" | ¾" | 1" | | | | | | | | |
| 1 | 4,850 | 4,100 | 2,700 | — | — | RES-C24H11 | | ½ | 1160 | 23 | .36 | 20° | 658 |
| 2 | 5,650 | 4,800 | 2,600 | — | — | RES-C24J11 | | ½ | 1160 | 26 | .56 | 26° | 660 |
| 3 | 6,050 | 5,600 | 5,050 | 4,300 | 3,100 | RES-C24K17 | 24 | ¾ | 1750 | 43 | .83 | 14° | 665 |
| 4 | 7,150 | 6,700 | 6,200 | 5,450 | 4,150 | RES-C24L17 | | 1 | 1750 | 48 | 1.14 | 19° | 670 |
| 5 | 8,400 | 7,850 | 7,300 | 6,600 | 5,400 | RES-C24M17 | | 1½ | 1750 | 53 | 1.65 | 24½° | 674 |
| 6 | 7,250 | 5,800 | 3,050 | — | — | RES-C30J8 | | ½ | 870 | 21 | .53 | 20½° | 781 |
| 7 | 8,050 | 7,200 | 5,700 | 3,800 | — | RES-C30K11 | | ¾ | 1160 | 33 | .81 | 15° | 785 |
| 8 | 9,400 | 8,400 | 7,100 | 5,700 | — | RES-C30L11 | 30 | 1 | 1160 | 36 | 1.10 | 20° | 791 |
| 9 | 11,000 | 9,900 | 8,400 | 6,400 | 4,600 | RES-C30M11 | | 1½ | 1160 | 38 | 1.65 | 25° | 795 |
| 10 | 10,800 | 10,250 | 9,700 | 9,000 | 8,000 | RES-C30N17 | | 2 | 1750 | 73 | 2.26 | 12½° | 802 |
| 11 | 12,950 | 12,400 | 11,800 | 11,000 | 10,200 | RES-C30P17 | | 3 | 1750 | 79 | 3.21 | 17° | 819 |
| 12 | 16,900 | 16,250 | 15,600 | 14,750 | 13,800 | RES-C30Q17 | | 5 | 1750 | 85 | 5.32 | 27° | 835 |
| 13 | 7,200 | 5,500 | 2,800 | — | — | RES-C36J8 | | ½ | 870 | 26 | .53 | 8° | 984 |
| 14 | 10,250 | 8,950 | 6,400 | — | — | RES-C36K8 | | ¾ | 870 | 27 | .82 | 15° | 988 |
| 15 | 12,100 | 10,600 | 8,300 | 5,000 | — | RES-C36L8 | | 1 | 870 | 28 | 1.19 | 20° | 993 |
| 16 | 14,200 | 12,500 | 9,800 | 6,200 | — | RES-C36M8 | | 1½ | 870 | 30 | 1.66 | 27° | 998 |
| 17 | 13,700 | 12,750 | 11,550 | 9,900 | 7,500 | RES-C36N11 | 36 | 2 | 1160 | 46 | 2.20 | 15° | 1005 |
| 18 | 17,350 | 16,200 | 15,000 | 13,300 | 10,400 | RES-C36P11 | | 3 | 1160 | 48 | 3.27 | 22½° | 1024 |
| 19 | 19,000 | 18,400 | 17,700 | 17,000 | 16,200 | RES-C36Q17 | | 5 | 1750 | 86 | 5.50 | 13° | 1037 |
| 20 | 23,700 | 23,000 | 22,300 | 21,500 | 20,650 | RES-C36R17 | | 7½ | 1750 | 91 | 8.30 | 19° | 1078 |
| 21 | 27,750 | 27,100 | 26,100 | 25,200 | 24,200 | RES-C36S17 | | 10 | 1750 | 109 | 11.09 | 24½° | 1107 |
| 22 | 10,500 | 8,500 | 6,250 | 3,000 | — | RES-C42L8 | | 1 | 870 | 26 | 1.08 | 7° | 1268 |
| 23 | 15,400 | 13,600 | 11,100 | 8,000 | — | RES-C42M8 | | 1½ | 870 | 30 | 1.63 | 13½° | 1273 |
| 24 | 17,000 | 15,400 | 13,000 | 9,500 | 5,250 | RES-C42N8 | 42 | 2 | 870 | 33 | 2.09 | 16° | 1297 |
| 25 | 21,600 | 19,700 | 17,150 | 13,200 | 9,250 | RES-C42P8 | | 3 | 870 | 36 | 3.35 | 25° | 1316 |
| 26 | 24,500 | 23,000 | 21,600 | 20,000 | 17,900 | RES-C42Q11 | | 5 | 1160 | 55 | 5.50 | 18½° | 1335 |
| 27 | 19,100 | 16,500 | 12,750 | — | — | RES-C48M6 | | 1½ | 680 | 26 | 1.65 | 15° | 1577 |
| 28 | 22,500 | 20,000 | 16,000 | — | — | RES-C48N6 | | 2 | 680 | 28 | 2.22 | 20° | 1598 |
| 29 | 25,000 | 22,000 | 17,500 | — | — | RES-C48P6 | | 3 | 680 | 31 | 3.30 | 25° | 1796 |
| 30 | 16,600 | 14,250 | — | — | — | RES-C48N8 | 48 | 2 | 870 | 35 | 2.15 | 7½° | 1572 |
| 31 | 22,750 | 21,000 | 18,500 | 14,750 | 11,750 | RES-C48P8 | | 3 | 870 | 40 | 3.29 | 13½° | 1587 |
| 32 | 28,500 | 26,500 | 24,250 | 21,300 | 15,500 | RES-C48Q8 | | 5 | 870 | 45 | 5.57 | 20° | 1754 |
| 33 | 32,500 | 31,200 | 29,500 | 28,000 | 26,000 | RES-C48R11 | | 7½ | 1160 | 67 | 8.19 | 15° | 1760 |
| 34 | 38,000 | 36,400 | 34,800 | 33,000 | 31,400 | RES-C48S11 | | 10 | 1160 | 75 | 11.00 | 20° | 1796 |
| 35 | 21,400 | 19,000 | 14,500 | 9,350 | — | RES-C54N6 | | 2 | 680 | 36 | 2.09 | 10° | 2086 |
| 36 | 26,100 | 23,500 | 19,500 | 13,500 | 9,250 | RES-C54P6 | | 3 | 680 | 39 | 3.31 | 15° | 2284 |
| 37 | 35,000 | 32,400 | 28,500 | 21,000 | 16,000 | RES-C54Q6 | 54 | 5 | 680 | 47 | 5.47 | 24° | 2457 |
| 38 | 30,250 | 28,400 | 26,000 | 23,000 | 18,500 | RES-C54Q8 | | 5 | 870 | 57 | 5.45 | 12° | 2242 |
| 39 | 39,000 | 37,000 | 34,500 | 32,000 | 28,000 | RES-C54R8 | | 7½ | 870 | 66 | 8.20 | 19° | 2277 |
| 40 | 40,000 | 38,500 | 36,900 | 35,250 | 33,200 | RES-C54S11 | | 10 | 1160 | 104 | 11.12 | 12° | 2284 |
| 41 | 25,500 | 22,000 | 18,000 | 12,000 | 7,000 | RES-C60P6 | | 3 | 680 | 44 | 3.27 | 8° | 2544 |
| 42 | 36,750 | 34,000 | 30,500 | 25,500 | 18,500 | RES-C60Q6 | | 5 | 680 | 48 | 5.42 | 15° | 2713 |
| 43 | 31,250 | 28,500 | 25,400 | 21,850 | 18,000 | RES-C60Q8 | 60 | 5 | 870 | 63 | 5.55 | 7° | 2502 |
| 44 | 40,500 | 38,000 | 35,250 | 32,400 | 28,750 | RES-C60R8 | | 7½ | 870 | 72 | 8.26 | 11½° | 2538 |

1—Performance shown is for supply operation or recirculation operation and includes resistance of dampers. Performance for exhaust operation will be slightly less due to hood restriction.

2—The first five letters of model number identify fan type, drive configuration and style. (Drive configuration has been omitted in table. Insert "D" for direct drive or "B" for belt drive to complete model number.) The next two numbers indicate fan size; the next letter identifies motor horsepower; the last number (or numbers) indicates RPM in hundreds. Example: Model RESDC24H11 is a Type RES, direct drive, Style C, 24" size, ½HP, 1160 RPM.

3—The sound ratings shown are loudness values in fan sones at 5 ft. (1.5m) in a hemispherical free field calculated per AMCA Standard 301. Values shown are for Installation Type A: free inlet fan sone levels. The sound ratings shown are at 0" static pressure.

4—Maximum brake horsepower (BHP) within the catalog performance range. On belt drive models, BHP does not include drive losses. Bearing losses are included. BHP at most static pressures listed is less than that shown, in some cases substantially less. For specific BHP values at individual static pressure points contact your American Coolair representative. Because of the cooling the motor receives from the moving air stream, motor loading beyond the nominal nameplate rating on these American Coolair fans does not overheat the motor and is within NEMA recommended limits and motor service factor. It is not detrimental to the motor and is economically desirable.

5—All models use a four bladed adjustable pitch propeller with cast aluminum airfoil blades. Alternate blades are pitched 180° apart. Blade pitch in degrees from plane of hub is shown.

6—To convert air performance (CFM and SP) and power (BHP) to metric units, multiply CFM x .000472 to obtain cubic meters per second. Multiply SP x 248.36 to obtain Pa (Pascals). Multiply BHP x .7457 to obtain Kilowatts.

Example: 3904 CFM x .000472 = 1.8427 Cubic meters per second.
0.125 SP x 248.36 = 31.05 Pascals
0.886 BHP x .7457 = 0.661 Kilowatts

Installation, selection and maintenance

INSTALLATION: RE and RES PRVs are shipped in three packages for quick assembly and installation on the roof curb. Mounting, installation and maintenance instructions are included.

The plenum, complete with fan and dampers, can be lowered through the roof opening with flanges attached or raised from below with flanges temporarily unbolted until the top of the plenum is above the roof opening. The plenum is then attached to the roof curb with the flanges resting on top of the curb.

Next, the curb cap or base should be securely attached to the roof curb.

The wind shroud or hood is then easily attached to the base.

Curb should be level.

Before connecting motor to power source, check motor nameplate to be sure of correct phase and voltage.

Make sure propeller turns freely without striking fan frame or any foreign object which may interfere with its operation.

SELECTION: Choice of specific model(s) should be based on exhaust or supply CFM requirements. Recirculation velocities should be considered with regard to human comfort at floor levels.

SOUND RATINGS: When sound is a critical problem, ventilator selection should be made from accurate sound data. The only completely accurate sound ratings are octave band sound power levels. American Coolair can furnish these for each PRV model on request. With this data the acoustical engineer can accurately predict on-the-job sound levels. Published sound ratings are in Sones. American Coolair can also provide sound ratings in dBA. Both Sones and dBA are sound pressure ratings which have been calculated from the octave band sound power ratings. They may be used as a guide in ventilator selection where sound is NOT a critical problem.

MAINTENANCE: American Coolair's Type RE and Type RES PRVs are factory lubricated for extended service without re-lubrication. Belt drive models use pillow-block ball bearings and should be lubricated annually or more frequently, depending upon conditions and operating cycle. Refer to maintenance instructions shipped with fan. Instructions for motor lubrication are supplied by motor manufacturer. On belt drive units, re-check belt tension as part of maintenance routine to assure maximum efficiency and belt life.

Accessories

American Coolair provides a long list of accessories that can be selected from our Form 610-15. Several accessories commonly used with Type RE and Type RES PRVs include:

SAFETY DISCONNECT SWITCH: Prevents accidental starting of PRV. NEMA I enclosure. Shipped separate for mounting to fan/damper plenum after installation through roof opening.

PREFABRICATED ROOF CURB: You may specify surface mount or bulb T-style 8-inch standard height curbs. Curbs are welded galvanized steel, insulated, with wood nailer. Construction to accommodate single or double pitch roof slope is also available. (Special height plenum may be required depending on amount of roof slope.)

Curb size is different from standard American Coolair curbs used with other type PRVs. Specify "curb for type RE-RES PRV".

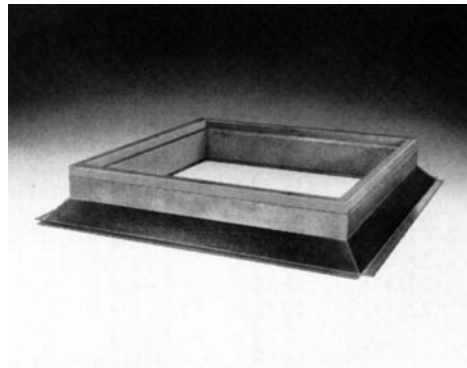

SAFETY GUARD: Attaches to interior opening at bottom of plenum. The guard is made of PVC coated steel wire with $\frac{1}{2}$ " x 1" spacing. If four-way diffuser is needed, this accessory is not available.

SPARK RESISTANT CONSTRUCTION: For hazardous locations, all RE and RES PRVs standardly use cast aluminum airfoil blade assemblies and any PRV can be ordered with explosion-proof motors. Motors only qualify for Class I Group D and Class II Groups F & G hazards.

PROTECTIVE COATINGS: For most applications, the American Coolair powder coating system will provide the necessary surface protection for painted parts. This system includes a thermosetting epoxy powder coating to an average thickness of 3 mils and

baked at 400 degrees Fahrenheit for hardness, impact resistance, adhesion and chemical resistance.

The fan assembly on all models, and the curb cap on Type RE units are heavy gauge steel using all welded construction throughout. The standard finish is epoxy paint; however, additional corrosion protection is available by specifying hot dip galvanizing.

The plenum on 54" and 60" size units is heavy gauge steel finished with epoxy paint.

The wind shroud on Type RE units, the hood and base on Type RES units and the plenum on 24" through 48" size units are fabricated of galvanized steel. A finish coat of epoxy can be specified on the exterior of all galvanized components if desirable.

For applications that require more specialized surface protection, American Coolair offers alternatives: 6 mil epoxy or hot dip galvanizing, and others. For more information about special protective coatings, contact your American Coolair representative.

FOUR-WAY DIFFUSER: For directing airflow from the plenum into the plant area as desired. It is shipped mounted to the plenum. The 14 gauge frame and 20 gauge blades are constructed of galvanized steel.

MAGNETIC LATCHES: (Type RE) The addition of magnetic latches can minimize "damper flap" and accidental venting when unit is not in use.

OUTLET GUARD: (Type RE) The outlet guard mounts on top edge of wind shroud. It is constructed of 1" x 1", 14-gauge galvanized wire mesh. This guard prevents entry of foreign objects that might damage units.

MODULATING DAMPER MOTOR (Type RES): For use when it is desirable to maintain a predetermined inside temperature by mixing varying amounts of recirculated plant air and cool outside air. The modulating motor, complete with linkage, electronic temperature controller and transformer are mounted within the plenum. A remote temperature sensor with set point is also provided for mounting and wiring by the customer. Primary voltage must be specified.

FILTERS: (Type RES) When specified, units come with a set of filters for mounting during installation. They are nominal 2-inch thick, permanent, cleanable filters as manufactured by Research Products Corp., or equivalent. They are factory coated with filter

adhesive. Filters are easily cleaned by flushing with water. Adhesive must be reapplied after cleaning. Filter racks are designed for easy filter removal and replacement. Standard filters are designed to handle air velocities up to 650 feet per minute. They should not be specified where ambient temperature will exceed 120°F.

BIRD SCREEN: (Type RES) This galvanized wire mesh will prevent entry of birds and rodents.

UNDERCOATING: (Type RES) A special undercoating is factory-applied to interior surfaces of hood and base. It reduces condensation and adds sound-deadening insulation.

FIBERGLASS INSULATION: (Type RES) The inner crown of the hood and inside the base section of Type RES units can be lined with one-inch thick fiberglass insulation to minimize condensation in cold weather.

REVERSING SWITCH: For single phase motor operation, American Coolair offers this reversing switch to control fan motor for either exhaust or supply operation. It is essential for fan rotation to stop entirely before reversing direction. Therefore, a separate ON/OFF switch is required. American Coolair's reversing switch is shipped separately for installation in a convenient location.

ELECTRICAL CONTROLS: Normally the needed electrical controls are provided by those involved with the fan installation.

LIMITED WARRANTY

In the sale of its products, American Coolair Corporation agrees to correct, by repairs or replacement, any defects in workmanship or materials that develop under proper and normal use during the period of one year from the date of shipment from the factory. Any product or part proving, upon American Coolair's examination, to be defective during the limited warranty period will be repaired or replaced, at American Coolair's option, f.o.b. factory, at no charge.

Deterioration or wear caused by chemicals, abrasive action or excessive heat shall not constitute a defect. Motors are guaranteed only to the extent of the manufacturers warranty.

American Coolair's limited warranty does not apply to any of its products or parts that have been subjected to accidental damage, misuse by the user, unauthorized modifications, improper installation or electrical wiring, or lack of proper lubrication or other service requirements as established by American Coolair.

Repairs or replacements provided under the above terms shall constitute fulfillment of all American Coolair's obligations with respect to this limited warranty.

THE LIMITED WARRANTY STATED HEREIN IS IN LIEU OF ALL OTHER WARRANTIES, EXPRESS, STATUTORY OR IMPLIED, INCLUDING WITHOUT LIMITATION THAT OF MERCHANTABILITY AND FITNESS.

NO LIABILITY FOR REINSTALLATION COST OR FOR ANY SPECIAL, INDIRECT OR CONSEQUENTIAL DAMAGES OF ANY NATURE IS ASSUMED OR SHALL BE IMPOSED UPON AMERICAN COOLAIR.

WARNING



CAUTION

DO NOT INSTALL WITH MOVING PARTS WITHIN 8 FEET OF FLOOR OR GRADE LEVEL WITHOUT A GUARD THAT COMPLIES WITH OSHA REGULATIONS. **DO NOT** USE UNLESS ELECTRICAL WIRING COMPLIES WITH ALL APPLICABLE CODES. **DO NOT** WIRE WITHOUT PROVIDING FOR A POWER SOURCE DISCONNECT AT THE FAN ITSELF. **DO NOT** SERVICE EXCEPT BY A QUALIFIED MAINTENANCE TECHNICIAN AND ONLY AFTER DISCONNECTING THE POWER SOURCE. FAILURE TO OBSERVE THESE PRECAUTIONS CAN RESULT IN SERIOUS INJURY OR DEATH.



AMERICAN COOLAIR CORPORATION
P.O. Box 2300 • Jacksonville, Florida 32203
Phone: (904) 389-3646
Fax: (904) 387-3449 or (904) 381-7560
E-mail: fans@coolair.com

Represented By: