



Type

# NBF60

## High-Volume Agricultural Building Ventilator

### *Innovation*

With its six specifically engineered die-formed steel blades and deep-spun panel venturi, the NBF60 is designed to outperform the competition.

The NBF60 also features American Coolair's unique captured bearing arrangement which allows the blade hub to also serve as the driven sheave. Placing the belt load directly over the bearings greatly extends the life of the bearings, and with our exclusive optional dual-belt drive system, the NBF60 may be our most maintenance-friendly fan yet!

### *Durability*

The NBF60 incorporates a rugged, heavy-gauge steel welded angle-frame construction. The sturdy X-frame drive support design insures years of trouble-free operation.

For superior reliability in the harshest environments, the NBF60 blades, panel, frame, cone, and housing are all coated with a thermosetting epoxy coating to provide a protective finish rated excellent for hardness, impact resistance, adhesion, and chemical resistance. The finish is available in green or white.

### *Performance*

Move large volumes of air efficiently and economically with American Coolair's new NBF60 fan. Available in a slope wall housing, with or without a discharge cone, or as an air circulator, the NBF60 will simply move more air and use less power.



P.O. BOX 2300 JACKSONVILLE, FLORIDA 32203  
PHONE (904) 389-3646 FAX (904) 387-3449  
E-MAIL – agfans@coolair.com  
WEB – www.coolair.com

# PERFORMANCE RATINGS

The performance ratings listed below were obtained through testing by the Bioenvironmental and Structural Systems Lab (BESS Lab) at the University of Illinois. All fans were tested with a shutter and discharge guard, and some may also include an optional discharge cone as noted in the fan description. The fan housing was mounted flush to the test chamber face, as in an actual building installation. Power measurements were taken on the fan/motor combination and include motor efficiency and drive losses.



## CUBIC FEET PER MINUTE (CFM) AT STATIC PRESSURE

Fan Model	Motor HP	BESS Lab Test #	Fan RPM @0.05"	0" S.P.		.05" S.P.		.10" S.P.		.15" S.P.		.20" S.P.	
				CFM	CFM/Watt	CFM	CFM/Watt	CFM	CFM/Watt	CFM	CFM/Watt	CFM	CFM/Watt
<b>NBF Fan, Slope Wall Housing, Inlet Shutter &amp; Discharge Guard</b>													
MNBF60M	1 1/2	09248	321	31,100	20.8	29,100	19.1	27,100	17.5	24,300	15.3	20,200	12.3
MNBF60M Δ	1 1/2	09249	323	31,400	21.7	29,400	20.0	27,400	18.4	24,500	16.0	21,100	13.4
MNBF60N Δ	2	09246	365	35,100	17.0	33,500	15.9	31,800	14.8	29,800	13.7	27,700	12.4
MNBF60P Δ	3	09251	414	39,800	14.5	38,300	13.7	36,800	13.0	35,300	12.3	33,400	11.6
<b>NBF Fan, Slope Wall Housing, Inlet Shutter, Discharge Cone &amp; Guard</b>													
MNBF60M	1 1/2	09257	321	34,000	24.1	32,000	21.6	29,600	19.2	26,400	16.9	21,700	13.4
MNBF60M Δ	1 1/2	09254	325	34,300	24.2	32,300	22.0	30,100	19.9	27,000	17.1	22,700	14.0
MNBF60N Δ	2	09253	367	38,500	19.6	36,800	18.1	35,000	16.7	32,600	15.0	30,000	13.6
MNBF60P Δ	3	09252	413	43,300*	17.0*	41,800*	15.8*	40,100	14.8	38,290	13.5	36,110	12.6

Δ – 3-Phase Units

\* – Performance values for the static pressure indicated exceeded the BESS Lab airflow measurement capabilities and were calculated through regression and Affinity Laws analysis.

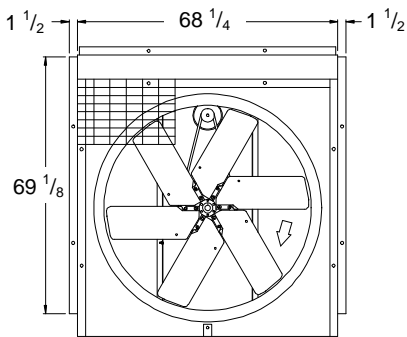

**MNBF60**

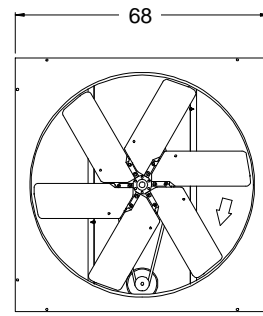
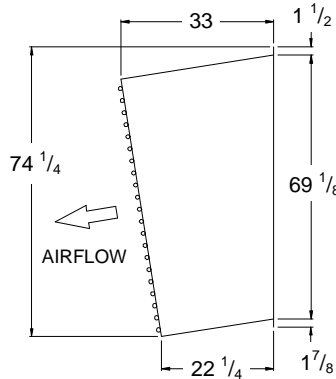

**NBF60**

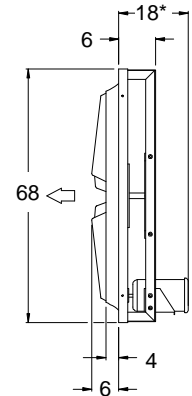

\* – Maximum length with 3HP motor

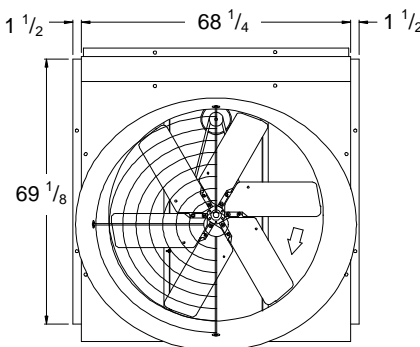

**MNBF60**

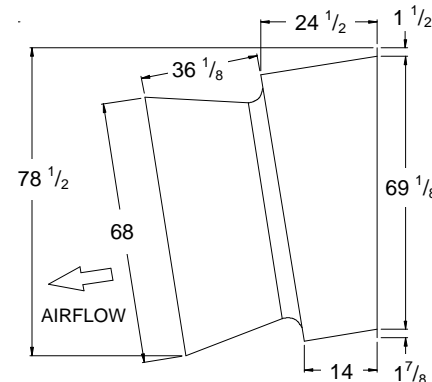

Dimensions in inches.

The required framed-in opening width for both the MNBF60 and MNBF60 is 68 3/4".

The required framed-in opening height depends on wall thickness:  
 For 2" thick walls, the height is 70"  
 For 4" thick walls, the height is 70 1/4".  
 For 6" thick walls, the height is 70 1/2".

ALL SPECIFICATIONS ARE SUBJECT TO CHANGE WITHOUT NOTICE.