

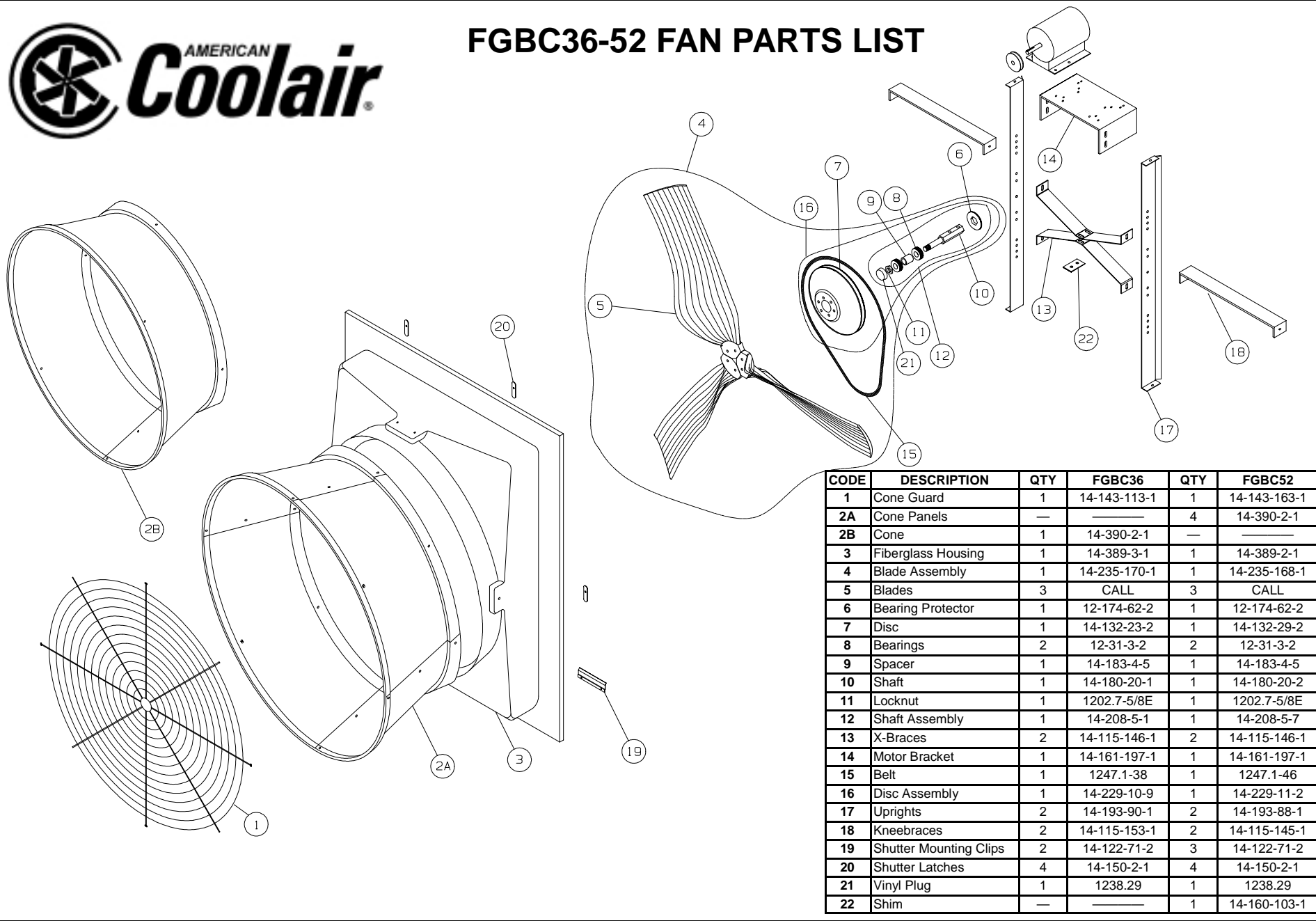

# FGBC36-52 FAN PARTS LIST



CODE	DESCRIPTION	QTY	FGBC36	QTY	FGBC52
1	Cone Guard	1	14-143-113-1	1	14-143-163-1
2A	Cone Panels	—	—	4	14-390-2-1
2B	Cone	1	14-390-2-1	—	—
3	Fiberglass Housing	1	14-389-3-1	1	14-389-2-1
4	Blade Assembly	1	14-235-170-1	1	14-235-168-1
5	Blades	3	CALL	3	CALL
6	Bearing Protector	1	12-174-62-2	1	12-174-62-2
7	Disc	1	14-132-23-2	1	14-132-29-2
8	Bearings	2	12-31-3-2	2	12-31-3-2
9	Spacer	1	14-183-4-5	1	14-183-4-5
10	Shaft	1	14-180-20-1	1	14-180-20-2
11	Locknut	1	1202.7-5/8E	1	1202.7-5/8E
12	Shaft Assembly	1	14-208-5-1	1	14-208-5-7
13	X-Braces	2	14-115-146-1	2	14-115-146-1
14	Motor Bracket	1	14-161-197-1	1	14-161-197-1
15	Belt	1	1247.1-38	1	1247.1-46
16	Disc Assembly	1	14-229-10-9	1	14-229-11-2
17	Uprights	2	14-193-90-1	2	14-193-88-1
18	Kneebraces	2	14-115-153-1	2	14-115-145-1
19	Shutter Mounting Clips	2	14-122-71-2	3	14-122-71-2
20	Shutter Latches	4	14-150-2-1	4	14-150-2-1
21	Vinyl Plug	1	1238.29	1	1238.29
22	Shim	—	—	1	14-160-103-1