



FARM PRODUCTS DIVISION
 MEMBER OF AMCA
 AMERICAN COOLAIR CORPORATION
 P.O. BOX 2300
 JACKSONVILLE, FLORIDA 32203
 PHONE (904) 389-3646 FAX (904) 387-3449
 E-MAIL - fans@coolair.com

FGBC36 and FGBCB52 FIBERGLASS FANS

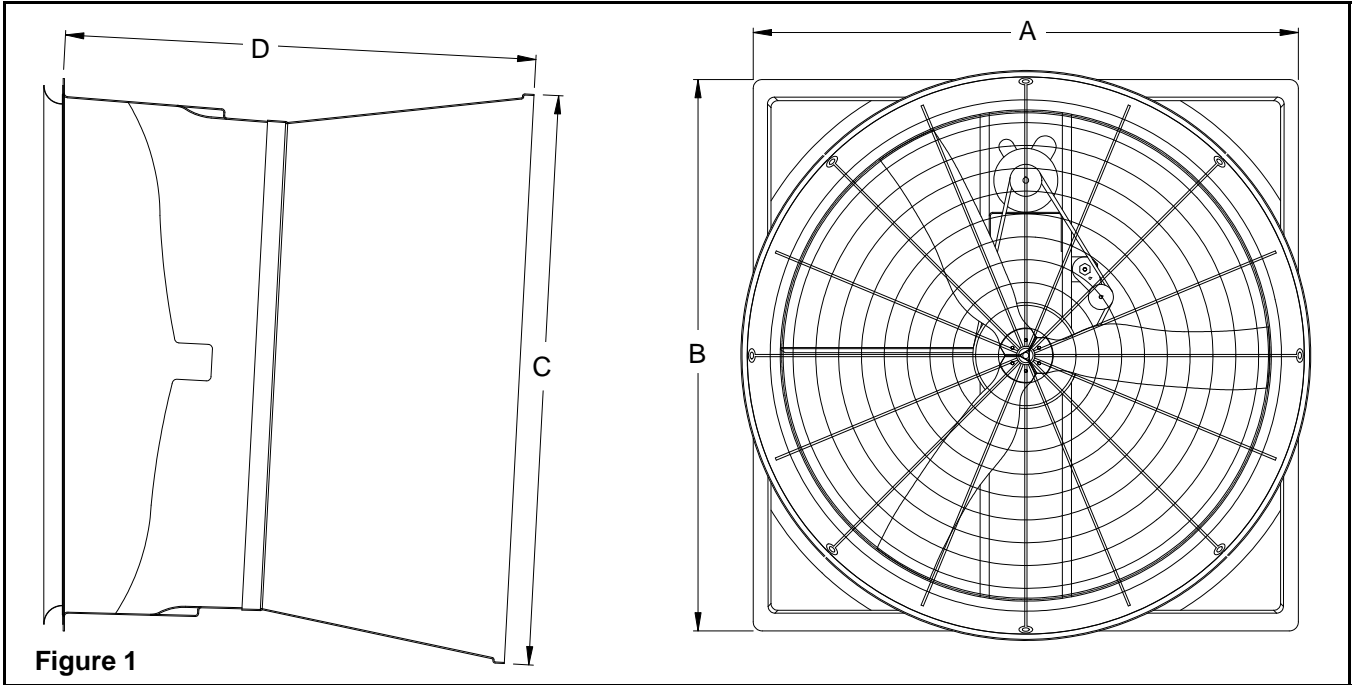

Figure 1

FAN SIZE	A	B	C	D	FRAMED ROUGH OPENING
36	44 1/2	44 3/4	48 1/8	46	41 1/2 X 41 1/2
52	59 3/4	60 3/8	51 5/8	62 1/2	56 7/8 X 56 7/8

FGBC36J and FGBCB52K * FGBCBE52L * FGBCB52L * FGBCB52M

UNPACKING

Inspect the fan for signs of shipping damage. It is the responsibility of the customer to report any shipping damage to the freight carrier.

WHAT SHOULD YOU FIND?

Fan, Shutter, Cone, Guard and Hardware Package

FRAMING INSTRUCTIONS

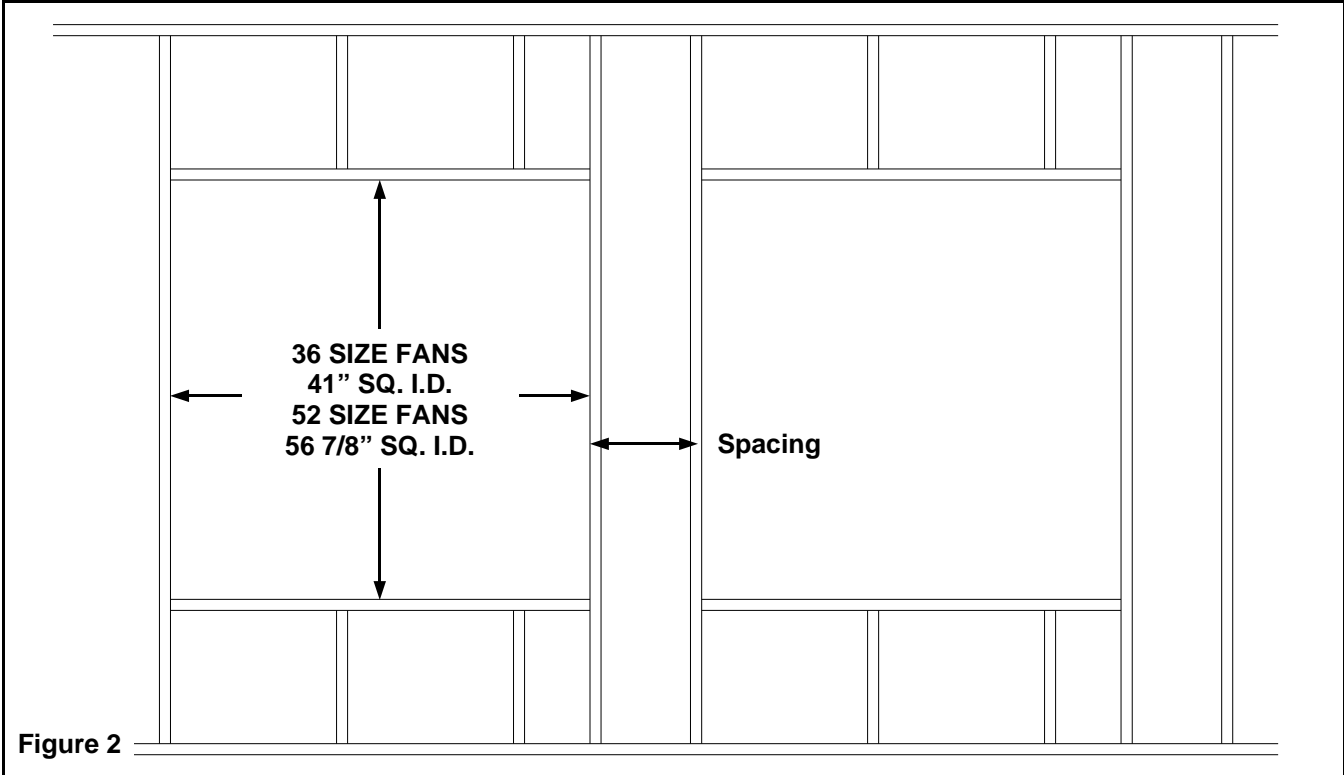

FRAME CONSTRUCTION

RECOMMENDED SPACING IS 12"

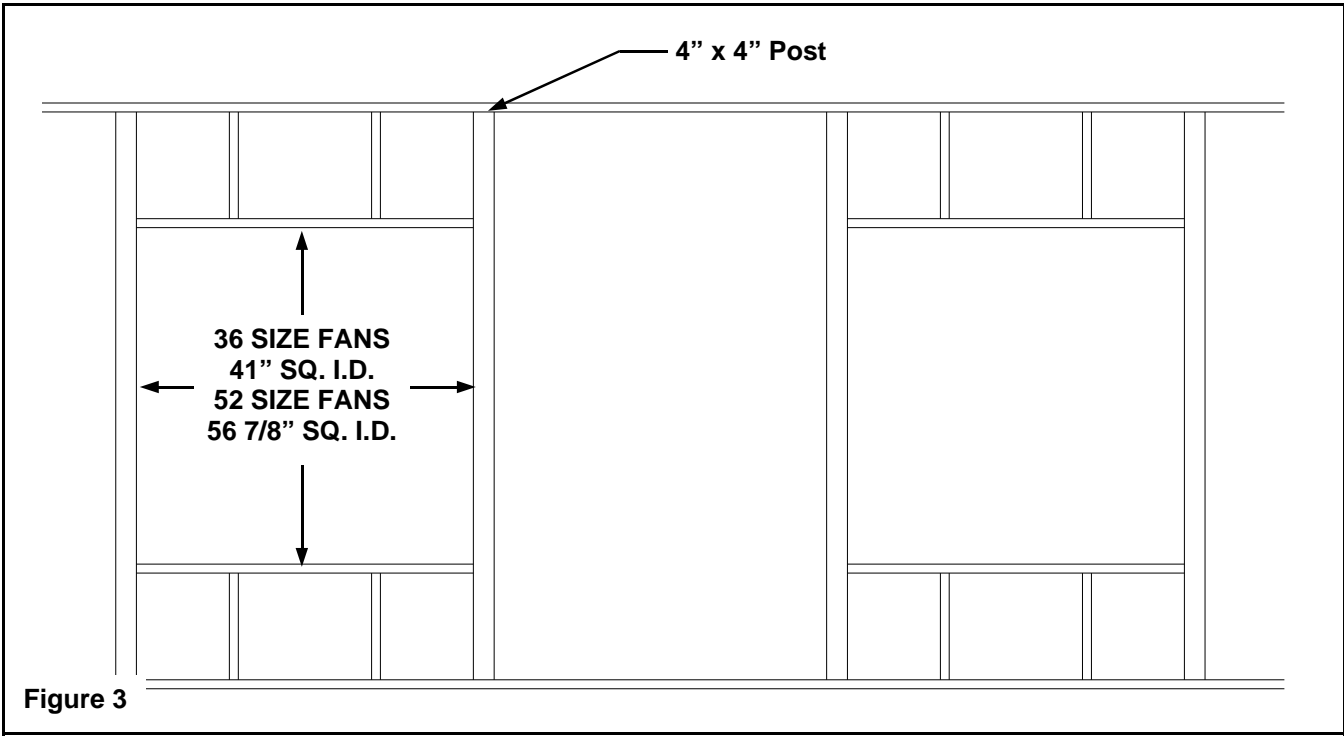

POST CONSTRUCTION

FAN HOUSING INSTALLATION INSTRUCTIONS

Insert the fan housing assembly through the framed opening of the wall from the inside, and secure it to the wall using four (4) of the 1/4" x 1 1/2" long rubber grommet lag screws through the pre-drilled holes in the side flanges of the fan housing. Check installation by eye and see if back of fan housing is planar and not twisted in the wall opening. The fan housing **MUST NOT** be installed out of square. Doing so will result in an out of round condition and blade rubbing will occur. If necessary, shim the housing so it is square. See Figure 4. Next, there are three (3) shutter mounting clips that are attached to the fan using six (6) of the 1/4" x 1 1/2" long rubber grommet lag screws through the pre-drilled holes in the bottom flange of the fan housing and into the framed opening. Finally, there are four (4) shutter latches and four (4) 7/8" O.D. rubber washers that are attached to the fan using four (4) of the 1/4" x 1 1/2" long rubber grommet lag screws. The rubber washer goes between the housing and the shutter latch. Place the shutter in the shutter mounting clips and match, mark and drill the four (4) 1/4" holes through the fan housing so shutter latch can rotate 90 degrees out of the way to remove the shutter. If necessary, shim the housing so it is square. Install flashing around fan and caulk to properly seal fan to wall.

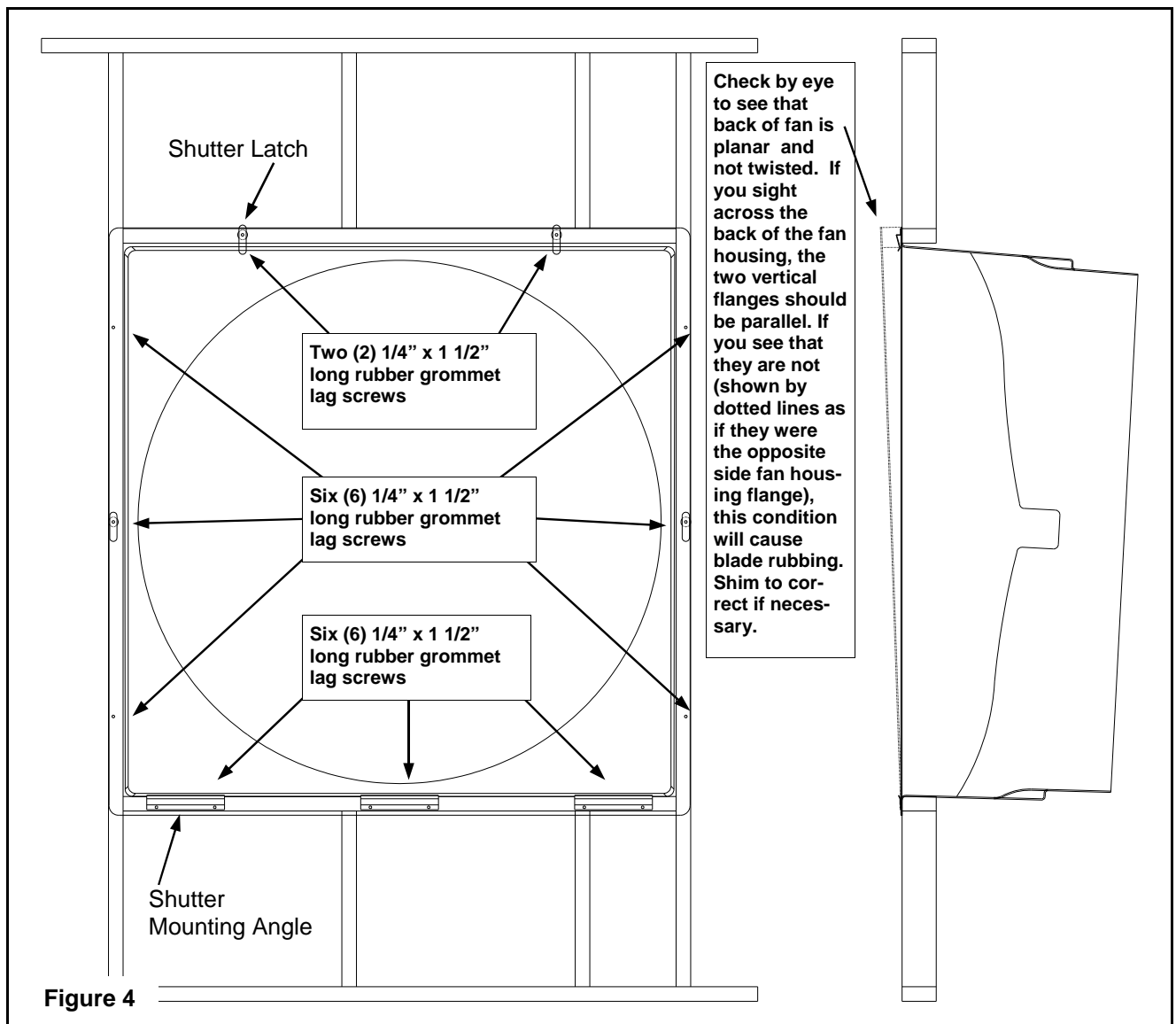

Figure 4

Note: Fan components have been removed for clarity of details.

ONE PIECE CONE INSTALLATION INSTRUCTIONS

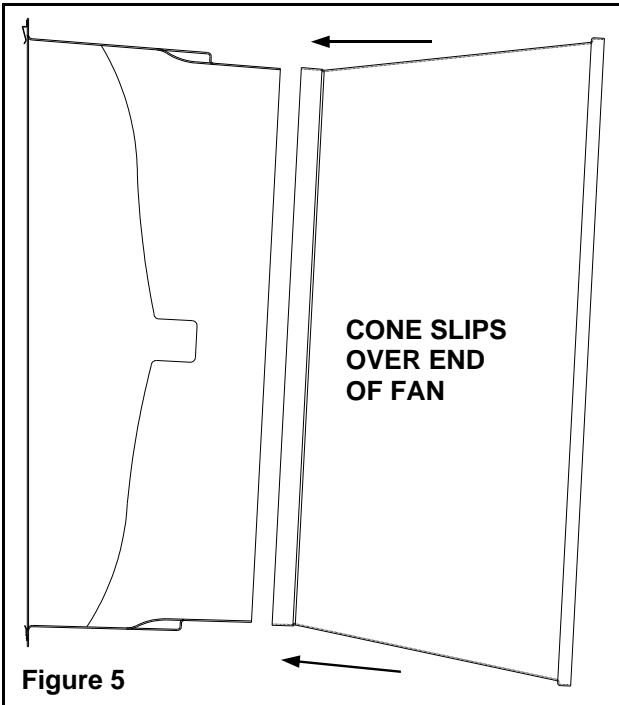

Figure 5

Side View of Fan Housing and Cone

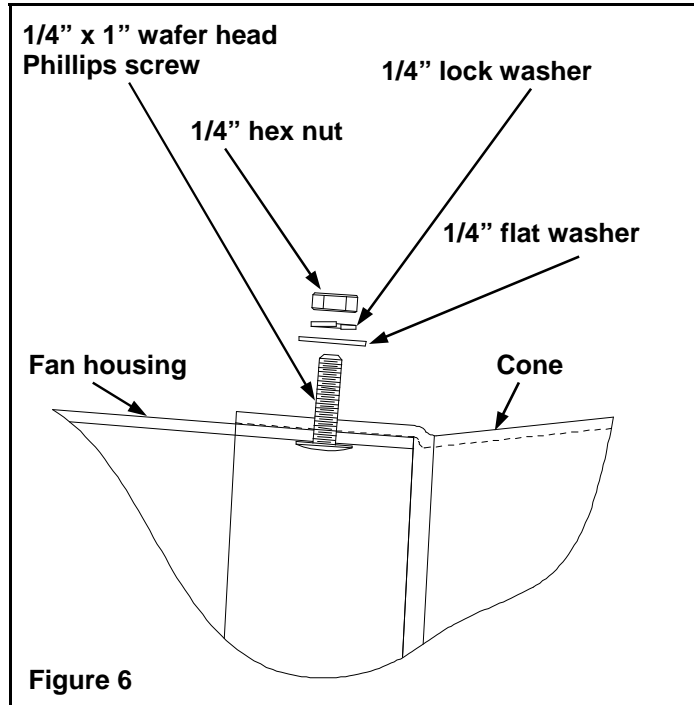

Figure 6

Detailed View of Hardware for Cone to Fan Housing

If you are installing 52" fans, skip this and refer to page 5, and follow **"FOUR PIECE CONE INSTALLATION INSTRUCTIONS"**

The one piece cone is tapered at the inlet end so it will fit snugly over the fan housing. Fasten the cone at the overlap with two (2) 1/4" x 1" hex head bolts, flat washers, lock washer and nut, only finger tight for now. See Figure 5A. Rotate cone while pushing it against the fan to line up the pre-drilled holes, and it will slide over the fan. See Figure 5. Fasten the cone to the fan housing with four (4) 1/4" x 1" wafer head Phillips screws, pushing the screws from inside the fan, through the fan housing and through the cone. Then, secure the cone to the fan housing on each screw with a flat washer, lock washer and hex nut. See Figure 6. Now, you can tighten all the hardware.

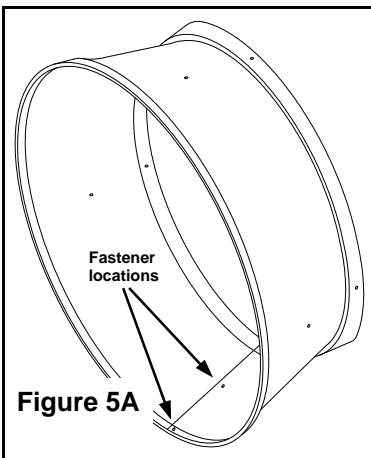

Figure 5A

FOUR PIECE CONE INSTALLATION INSTRUCTIONS

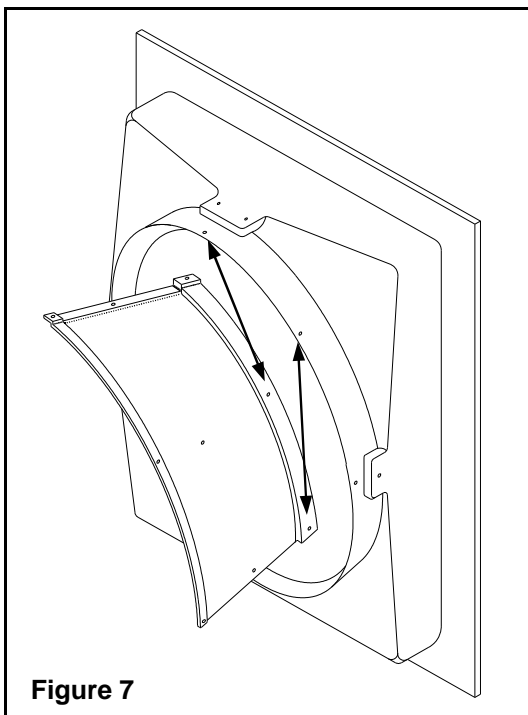

Figure 7

Fan Housing and Cone Quarter

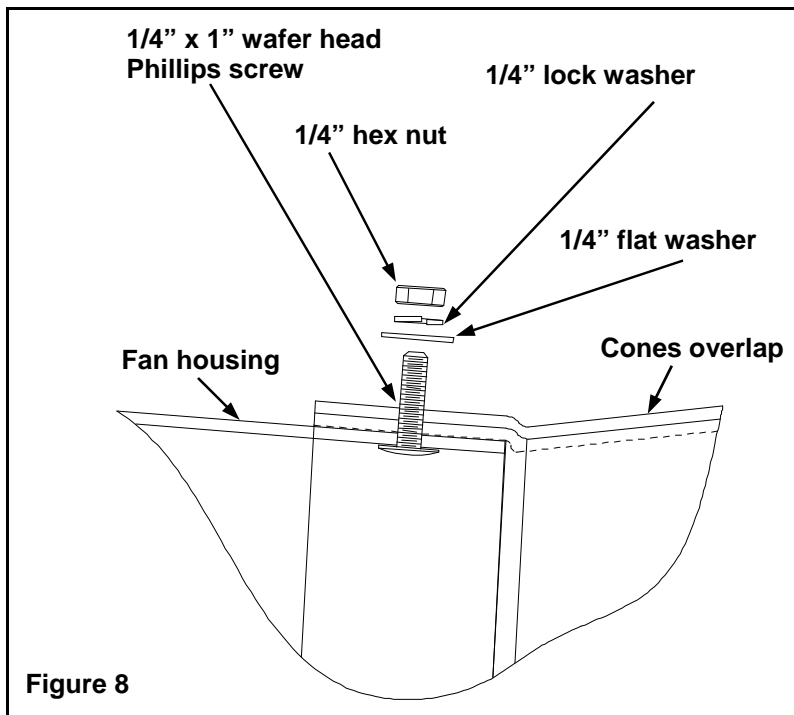

Figure 8

Detailed View of Hardware for Cone Quarters to Fan housing

If you are installing 36" fans, skip this and refer to page 4, and follow "ONE PIECE CONE INSTALLATION INSTRUCTIONS"

The four cone quarters are tapered at the inlet end so they will fit snugly over the fan housing. Place one cone quarter centered at the top of the fan to line up with the pre-drilled holes. Fasten the cone quarter to the fan housing with two (2) 1/4" x 1" truss head Phillips screws, pushing the screws from inside the fan, through the fan housing and through the cone quarter. Do this through the pre-drilled holes at the 12:00 position and the 1:30 position in the fan housing, and through the two (2) pre-drilled holes in the cone. See Figure 7. Then, secure the

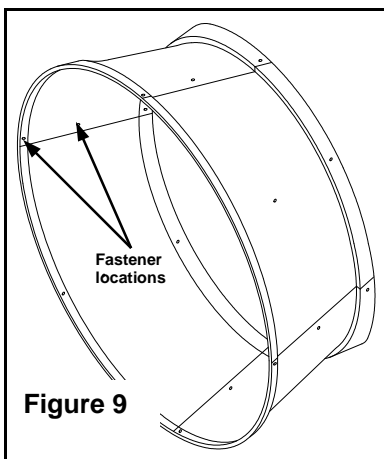
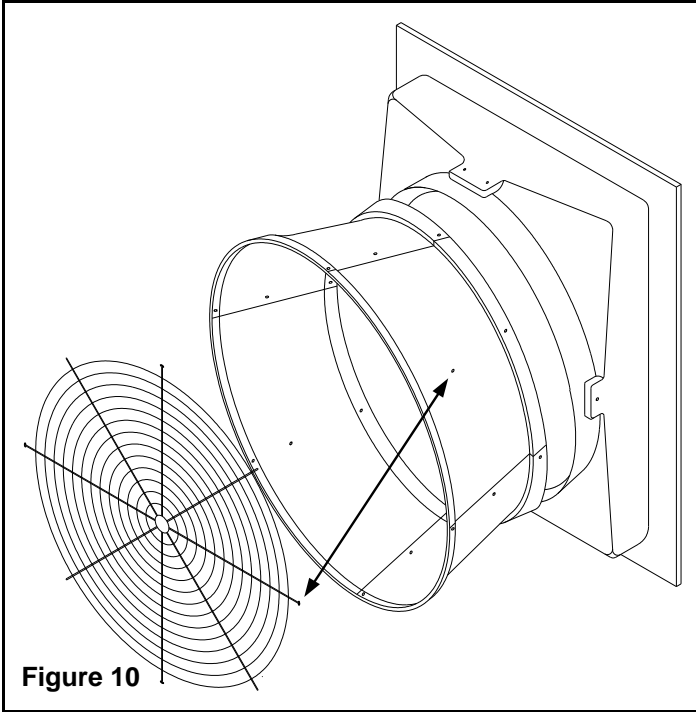

Figure 9

cone quarter to the fan housing with a flat washer, lock washer and hex nut (on each screw). See Figure 8. Fasten nut only finger tight at this time. Now, facing the fan outlet, in a counter clockwise direction, place another cone quarter to the left of the first one. This cone quarter will slip under the first so they overlap. Repeat the above hardware installation, and repeat for the remaining two cone quarters. When the fourth cone quarter is to be joined to the fan, you will need to remove the first screw so the two cone quarters will overlap. Finally, fasten the cone quarters where they overlap, two places per overlap, with one (1) 1/4" x 1" hex head bolt, flat washer, lock washer and hex nut. See Figure 9. Now, you can snug the cone quarters together and tighten all the hardware.

CONE GUARD INSTALLATION INSTRUCTIONS



View of Cone and Guard

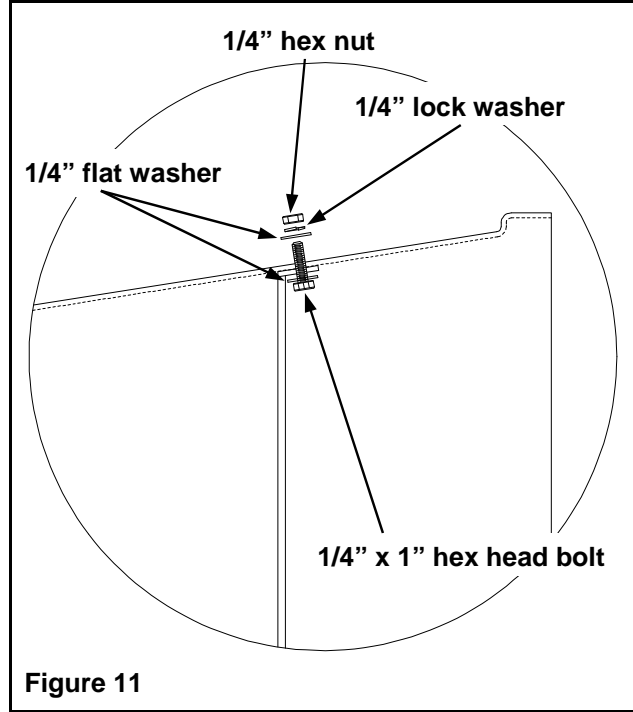

Detailed View of Hardware for Cone and Guard

WARNING
THE FAN MUST NOT BE OPERATED WITHOUT THE GUARD MOUNTED IN THE CONE.

Hold the guard out in front of you and visually line up the eyelets in the guard with the open pre-drilled holes in the cone. See Figure 10. Starting with the hole at the top, push one (1) of the four (4) 1/4" x 1" hex head bolts and 1/4" flat washers from the inside, through the guard eyelet and through the cone. Then, finger tighten the guard to the cone on each bolt with a flat washer, lock washer and hex nut. See Figure 11. Repeat this for the other three guard eyelet to cone connections. Once all hardware is in place, tighten to complete the assembly.

MOTOR MOUNTING INSTRUCTIONS

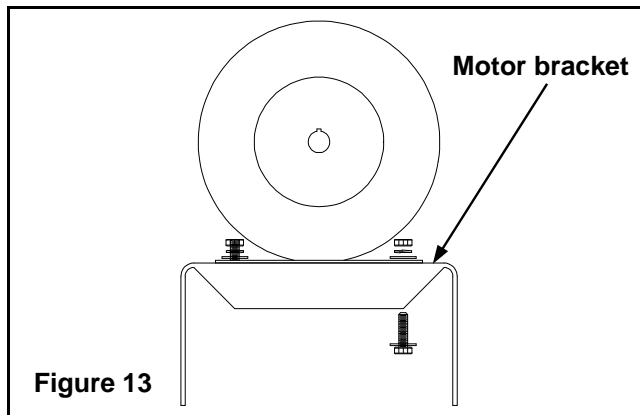

Figure 13

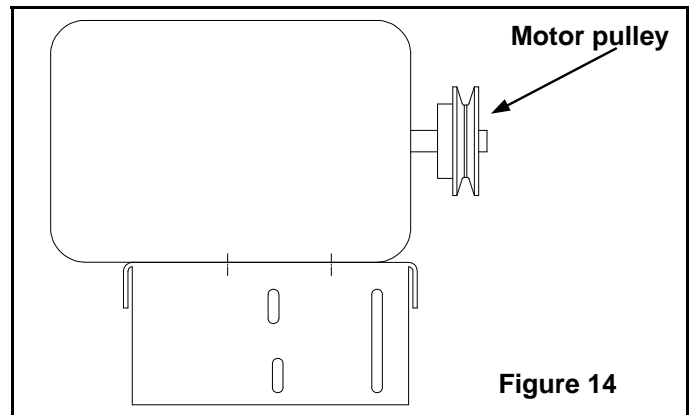

Figure 14

Assembly of Motor to motor bracket and pulley to motor shaft

The next step is to mount the motor to the motor bracket with four (4) 5/16" x 1" hex bolts, eight (8) flat washers, four (4) lock washers and four (4) hex nuts. See Figure 13. Slide the motor pulley on the motor shaft with the set screw(s) towards the motor, and insert the key. See Figure 14. Do not tighten the set screw until motor pulley is checked for proper alignment. See Figure 18.

AUTO BELT TENSIONER BELT TENSION INSTRUCTIONS

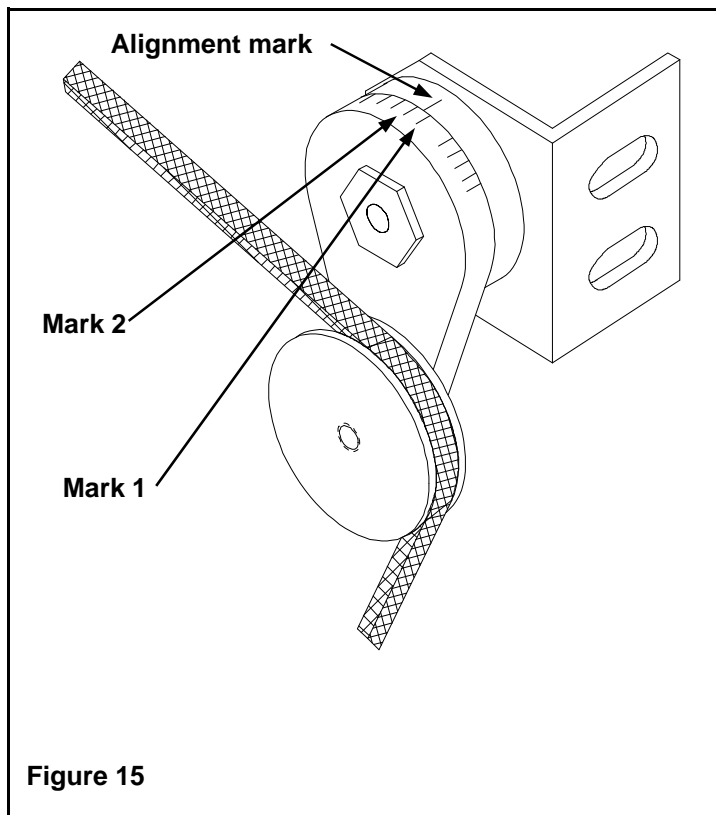
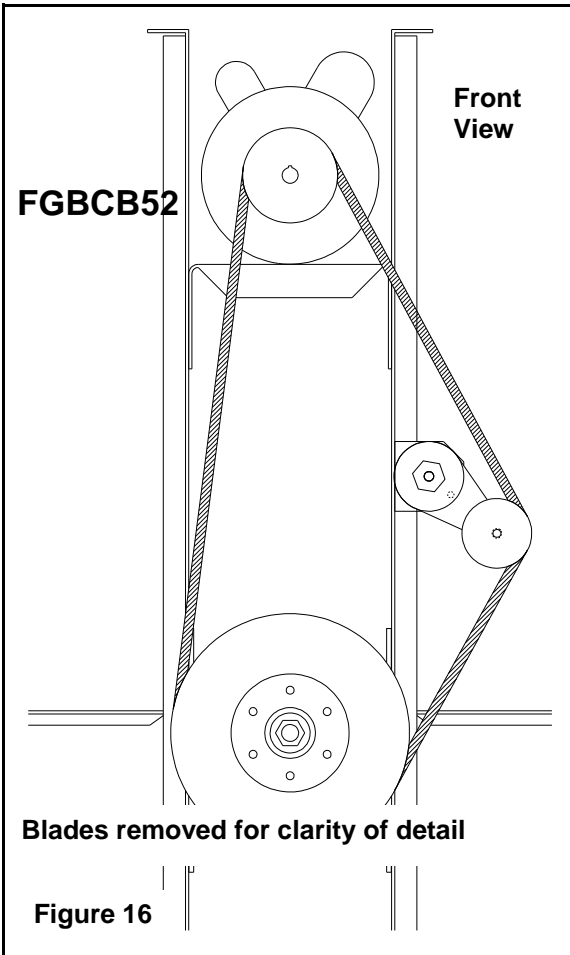

Figure 15

Belt Tensioner, Tensioner Bracket and Belt Showing Tension Alignment Marks

The next step is to thread the belt over the motor pulley and belt groove of the blade assembly. It will be necessary to push on the tensioner to get enough slack to thread the belt over the tensioner pulley. Check to see that the motor pulley is aligned with the other two pulleys. Note: the tensioner comes from the factory mounted and preset for adequate belt tension. If further tensioning is required, loosen the 3/8" bolt holding the tensioner to the tensioner bracket. Then, using a 15/16" wrench, rotate the tensioner assembly such that the alignment mark is between mark 1 and 2 on the idler arm. See Figure 15. Retighten the 3/8" bolt. Turn the blade assembly by hand to insure free rotation. **Do Not Over Tension The Belt.** This will cause premature belt and bearing failure. To check that the belt tension is not too high, place a finger midway between the fan pulley and motor pulley and push inward about 1/2". The force required to do this ***is not*** to exceed 5 pounds.

AUTO BELT TENSIONER BELT TENSION INSTRUCTIONS (cont.)



When viewed from the discharge end of the fan, the belt tensioner is located on the *right* upright of the FGBCB52. See Figure 16.

However, on the FGBC36, the belt tensioner is located on the *left* upright, when viewed from the discharge end of the fan. See Figure 17.

Motor/Pulley, Tensioner, Disc and Belt

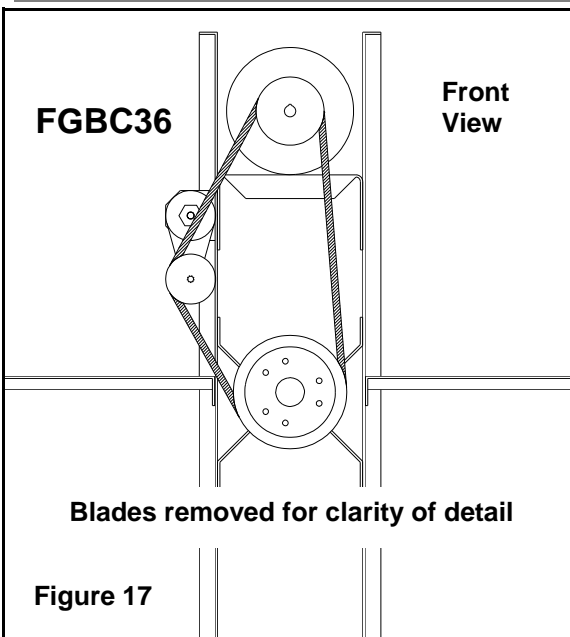

Motor/Pulley, Tensioner, Disc and Belt

BELT ALIGNMENT INSTRUCTIONS

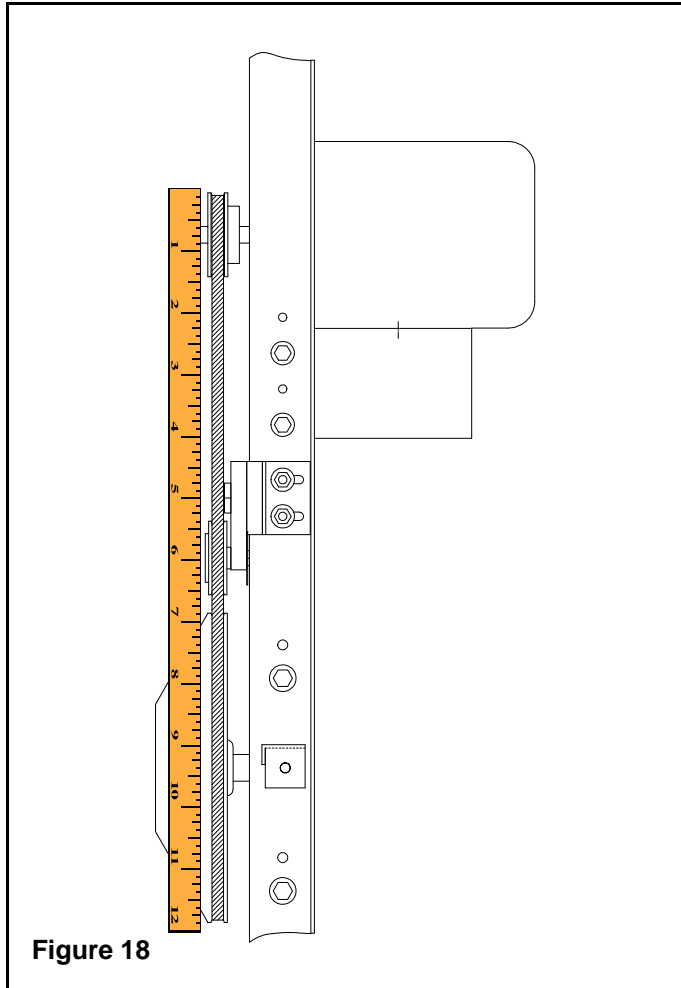

Figure 18

Detailed View of Properly Aligned Fan Sheaves

Spin the blade assembly by hand. Make sure that the blade assembly rotates freely and did not shift during shipment. If the blades rub in the fan housing on either side, it will be necessary to loosen the two (2) 3/8" bolts that secure the blade assembly's hexagonal shaft to the fan x-braces, center the blade assembly, and tighten the bolts to 25-30 ft-lbs torque. If the blades rub in the fan housing at the top or bottom, it will be necessary to loosen the four (4) 3/8" bolts that secure the fan x-braces to the fan uprights, center the blade assembly, and tighten the bolts to 25-30 ft-lbs torque. See parts lists on pages 12 and 13 for fan parts description. Next, the fan drive assembly should be checked for alignment. The fan drive assembly must be aligned for proper fan performance and to minimize pulley and belt wear. Before wiring and operating the fan, check that the drive pulley, driven disc and auto belt tensioner are aligned by using a straight edge such as a scale or yard stick. After making sure drive is aligned, tighten the motor pulley set screw(s). See Figure 18.

ELECTRICAL WIRING

Two tie wraps and adhesive bases are supplied to hold the motor wiring to the side of the fan and away from the rotating fan blade. All wiring must comply with national, state and local electrical codes. If fans are to be used for livestock ventilation to support life where failure could result in loss or injury, and continuous ventilation is essential, it is recommended that the fans be wired to individual electrical circuits, or at least two circuits per room. Any minimum ventilation fans should be on individual circuits.

WARNING

If the fans are going to be used for livestock building ventilation to support life where failure could result in loss or injury, the user must provide an adequate backup ventilation system and a failure alarm system. The user must accept the risk of such loss or injury from failure of the ventilation system.

CONSTRUCTION FOR WINTER WEATHER PROTECTION

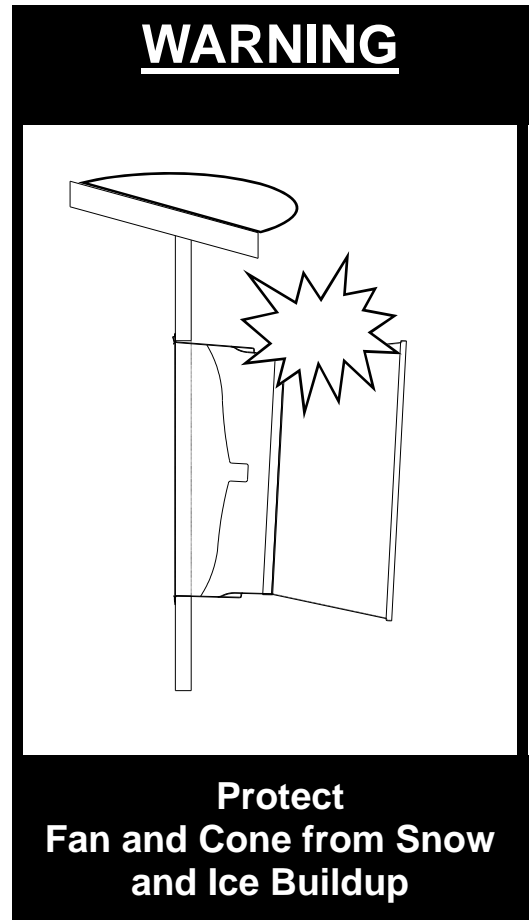
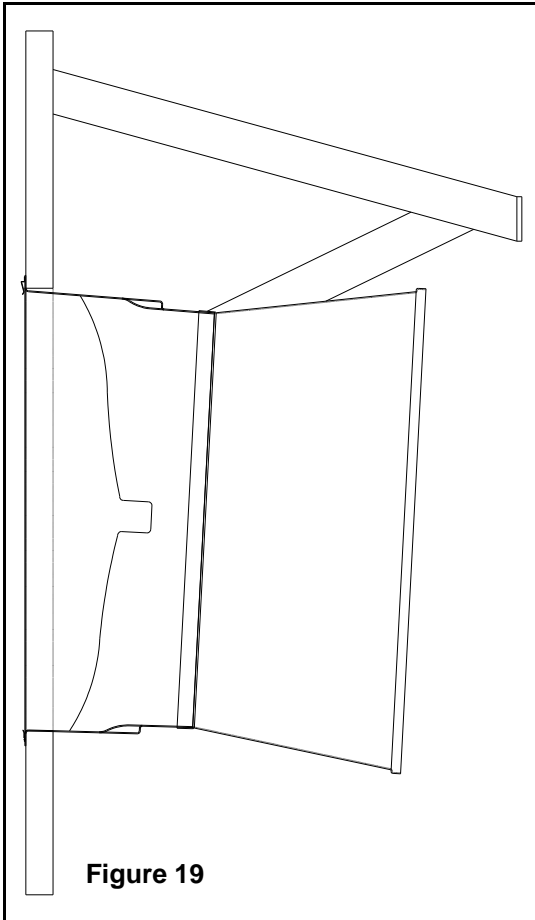

If your area is subject to snow, consideration must be taken to protect from the possibility of snow and ice building up on the roof and sliding down onto the fan and cone. One option is to build a small section of roof over the fan and cone. See Figure 19.

WARNING

Fan and/or cone damage caused by this type of external source WILL NOT be covered by AMERICAN COOLAIR warranties.

During winter months, you may not need to operate all of your fans. It is advisable to seal up those fans which will not be used during the colder months to minimize heat loss as well as condensation. To do this, turn the fan control off, and insulate the fan intake.

INITIAL STARTUP

1. With shutter not installed, spin the blade assembly by hand and make sure that the blade assembly rotates freely and did not shift during shipment. If the blades rub in the fan housing, refer to page 3 for instructions on correcting a housing installed out of square, and/or refer to page 9 for instructions on centering the blade assembly.
2. Check belt for proper tension. Refer to page 8 for instructions.
3. Check motor pulley, driven disc and idler pulley (if present) for proper alignment.
4. Check circuit phase, voltage and wiring connection against that shown on motor nameplate.
5. Check for correct fan rotation.
6. Replace the shutter. The fan is now ready for proper operation.

MAINTENANCE

CLEANING

- The fan should be cleaned regularly. Always turn the fan off before cleaning.
- The motor should be wiped with a cloth or a brush. This will keep the motor running cool. **DO NOT** pressure wash the motor.
- The blades should be wiped clean to maintain maximum air performance and minimize fan imbalance. **DO NOT** pressure wash the center of the disc assembly, or premature bearing failure may be induced.
- The inlet shutter should be wiped clean so blades will pivot freely and open completely. A dirty shutter can “starve” the fan of it’s air performance.

CHECK FASTENERS

Inspect all fasteners on the fan. This is a very important safety issue. If any loose hardware is found, tighten it immediately.

CHECK BELT TENSION

The belt must have proper tension to insure proper fan speed and maximum air performance. Refer to page 8 for instructions.

CHECK DRIVE ALIGNMENT

The belt must be properly aligned in the pulleys to minimize pulley and belt wear. Refer to page 9 for instructions.



FGBC36/FGBCB52 FAN PARTS LIST

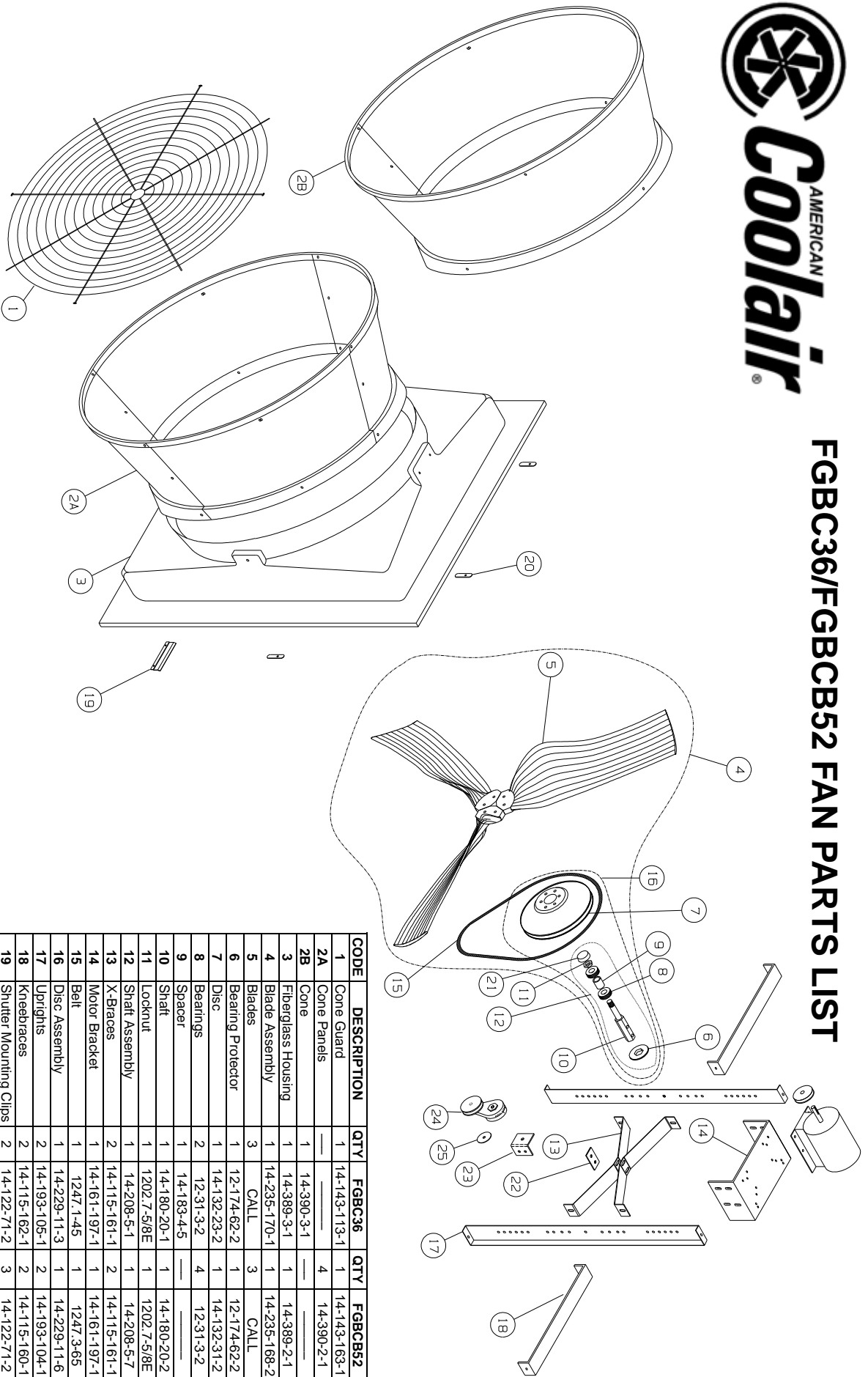

CODE	DESCRIPTION	QTY	FGBC36	QTY	FGBCB52
1	Cone Guard	1	14-143-13-1	1	14-143-163-1
2A	Cone Panels	—	—	4	14-390-2-1
2B	Cone	1	14-390-3-1	—	—
3	Fiberglass Housing	1	14-389-3-1	1	14-389-2-1
4	Blade Assembly	1	14-235-170-1	1	14-235-168-2
5	Blades	3	CALL	3	CALL
6	Bearing Protector	1	12-174-62-2	1	12-174-62-2
7	Disc	1	14-132-23-2	1	14-132-31-2
8	Bearings	2	12-31-3-2	4	12-31-3-2
9	Spacer	1	14-183-4-5	—	—
10	Shaft	1	14-180-20-1	1	14-180-20-2
11	Locknut	1	1202.7-5/8E	1	1202.7-5/8E
12	Shaft Assembly	1	14-208-5-1	1	14-208-5-7
13	X-Braces	2	14-115-161-1	2	14-115-161-1
14	Motor Bracket	1	14-161-197-1	1	14-161-197-1
15	Belt	1	1247.1-45	1	1247.3-65
16	Disc Assembly	1	14-229-11-3	1	14-229-11-6
17	Uprights	2	14-193-105-1	2	14-193-104-1
18	Kneebases	2	14-115-162-1	2	14-115-160-1
19	Shutter Mounting Clips	2	14-122-71-2	3	14-122-71-2
20	Shutter Latches	4	14-150-2-1	4	14-150-2-1
21	Vinyl Plug	1	1238.29	1	1238.29
22	Shim	—	—	1	14-160-103-1
23	Tensioner Bracket	1	14-158-69-1	1	14-158-69-1
24	Tensioner	1	1258.12-2	1	1258.12-2
25	Bearing Protector	1	14-126-79-1	1	14-126-79-1

This page left blank intentionally.

WARNING

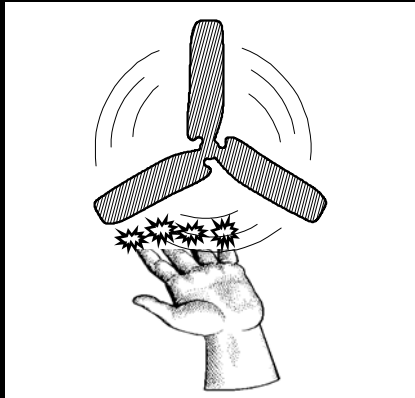

— Moving Parts —
Disconnect power
before servicing the
fan

WARNING

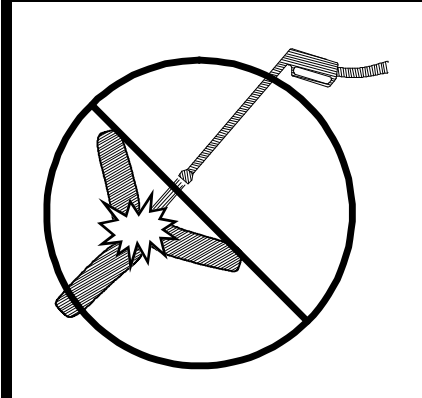

Precision Bearings
Do Not
Pressure Wash at
blade assembly center

WARNING

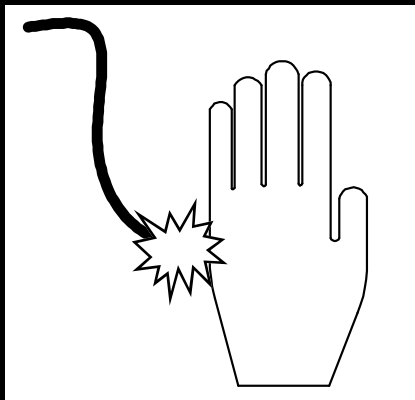

— High Voltage —
Disconnect power
before servicing the
fan

WARNING

CAUTION



DO NOT INSTALL FAN WITH MOVING PARTS WITHIN 8 FEET OF FLOOR OR GRADE LEVEL WITHOUT A GUARD THAT COMPLIES WITH OSHA REGULATIONS. **DO NOT** USE UNLESS ELECTRICAL WIRING COMPLIES WITH ALL APPLICABLE CODES. **DO NOT** WIRE WITHOUT PROVIDING FOR A POWER SOURCE DISCONNECT AT THE FAN ITSELF. **DO NOT** SERVICE EXCEPT BY A QUALIFIED MAINTENANCE TECHNICIAN AND ONLY AFTER DISCONNECTING THE POWER SOURCE. FAILURE TO OBSERVE THESE PRECAUTIONS CAN RESULT IN SERIOUS INJURY OR DEATH.



FARM PRODUCTS DIVISION

MEMBER OF AMCA
AMERICAN COOLAIR CORPORATION
P.O. BOX 2300
JACKSONVILLE, FLORIDA 32203
PHONE (904) 389-3646 FAX (904) 387-3449
E-MAIL - fans@coolair.com