

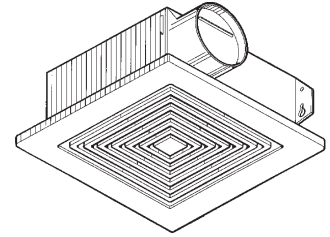

SPECIFICATION SHEET

CEILING FAN MODEL CF670A1151 (50 CFM)



Simple installation and dependability make this odor and moisture removing fan a real value.

FEATURES

GRILLE:

Matte white polymeric – blends well with any decor
Torsion spring grille mounting – no tools required

MOTOR:

Plug-in, permanently lubricated
Polymeric blower wheel
Snap in/out motor assembly for easy cleaning – no screws to drive or drop

HOUSING:

Compact, galvanized steel – attaches easily to wall or ceiling joists
Double strength mounting flanges with keyhole slots
Removable wiring cover – make connections away from tight corners
No electrical knockout to remove
Polymeric duct fitting with tapered sleeve for easy, positive duct connection
Quiet polymeric damper prevents cold backdrafts – no metallic clatter

U.L. Listed for use in tub/shower enclosure with GFCI branch wiring.

TYPICAL SPECIFICATION

Ventilator shall be Model CF670A1151.

Ventilator shall have galvanized steel housing with double-strength mounting flanges. It shall be ducted vertically (horizontally) to a roof cap (wall cap).

Motor assembly shall be removable and permanently lubricated.

Air delivery shall be not less and sound levels no greater than listed. All air and sound ratings shall be certified by AMCA. Units shall be U.L. Listed.

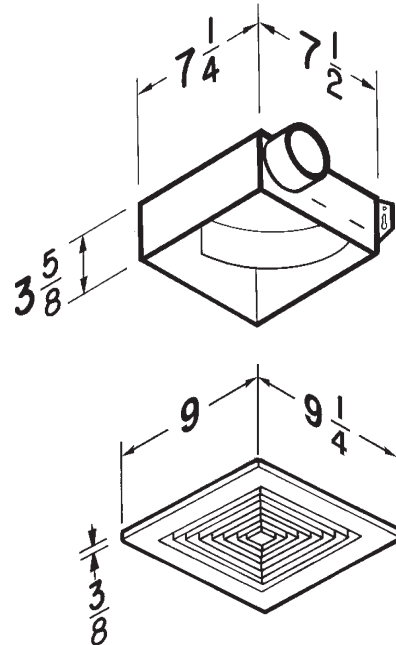

"American Coolair Corp. / ILG Industry" certifies that the models shown herein are licensed to bear the AMCA Seal. The ratings shown are based on tests and procedures performed in accordance with AMCA Publication 211 (and AMCA Publication 311 if sound is also certified) and comply with the requirements of the AMCA Certified Ratings Program"



UL listed for use over bathtubs and showers when connected to a GFCI-protected branch circuit.

PERFORMANCE RATINGS – CEILING FAN CF670A1151

AMCA LICENSED PERFORMANCE

Model No.		CFM/SONES @ Static Pressure (Ps – Inches of H ₂ O)					Volts	Watts	Nominal RPM	Duct Size
		0.0	0.1	.125	.250	.375				
CF670A1151	CFM	52	49	47	42	29	120	48	1870	3" Round
	Sones	3.9	4.3	4.4	4.6	5.5				

Performance ratings include the effects of inlet grille and backdraft damper in the airstream. Speed (RPM) shown is nominal. Performance is based on actual speed of test. The sound ratings are loudness values in fan sones at 5' (1.5m) in a hemispherical free field calculated per AMCA Std. 301. Values shown are for Installation Type B: free inlet fan sone levels. Performance shown is for Installation Type B: Free inlet, Ducted outlet.

WEIGHT

MODEL NO.	SHIPPING WT.
CF670A1151	4.2 lbs.



AMERICAN COOLAIR CORP. / ILG INDUSTRY
3604 MAYFLOWER ST.
JACKSONVILLE, FLORIDA 32205
TEL: 904-389-3646



"American Coolair Corp. / ILG Industry" certifies that the models shown herein are licensed to bear the AMCA Seal. The ratings shown are based on tests and procedures performed in accordance with AMCA Publication 211 (and AMCA Publication 311 if sound is also certified) and comply with the requirements of the AMCA Certified Ratings Program"



UL listed for use over bathtubs and showers when connected to a GFCI-protected branch circuit.