

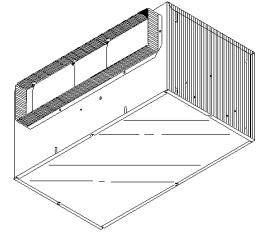

# SPECIFICATION SHEET

## IN-LINE VENTILATORS

- MODEL IL40LA1151 (400 CFM)
- MODEL IL50LA1151 (500 CFM)
- MODEL IL70LA1151 (700 CFM)



**Incredibly reliable. Unbelievably quiet. Offering the CFM choices you need at the lowest sound levels in the industry.**

### FEATURES

#### BLOWER:

- Low RPM for quiet operation
- Resilient anti-vibration mounts
- Balanced, polymeric, centrifugal blower wheel for quiet, efficient performance
- Permanently lubricated, thermally protected motor
- Plug-in motor rated at 120 VAC
- Designed for continuous operation

#### HOUSING:

- Rugged galvanized steel
- 4 1/2" x 18 1/2" duct connector
- May be installed in ceiling or wall (size permitting)
- 8-position mounting brackets for easy installation and greater adaptability to various mounting requirements
- Automatic backdraft damper located within duct connector
- Factory-shipped in horizontal discharge position
- Removable panel allows easy motor access without disturbing ductwork

### TYPICAL SPECIFICATION

Ventilator shall have galvanized steel housing. Housing to have adjustable mounting brackets and removable panel to allow motor access without disturbing ductwork.

Automatic backdraft damper to be located within duct connector. Duct connector, blower assembly and wiring plate shall be adjustable for either horizontal or vertical installation.

Blower unit shall be removable from housing and will have a polymeric, balanced, centrifugal-type blower wheel. Motor to be permanently lubricated and mounted with resilient anti-vibration mounts. RPM not to exceed number listed for each model.

Air delivery shall be no less and sound levels no greater than listed for each model. All air and sound ratings shall be certified by AMCA. Units to be UL listed.

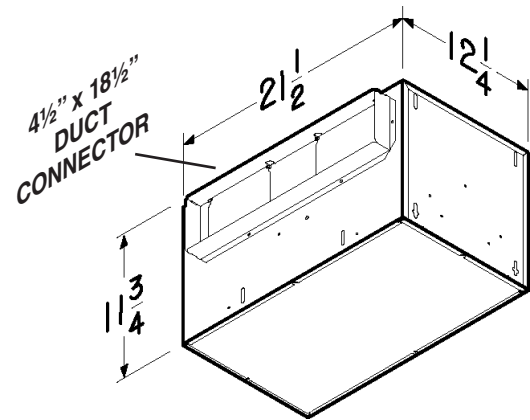

"American Coolair Corp. / ILG Industry" certifies that the models shown herein are licensed to bear the AMCA Seal. The ratings shown are based on tests and procedures performed in accordance with AMCA Publication 211 (and AMCA Publication 311 if sound is also certified) and comply with the requirements of the AMCA Certified Ratings Program"



UL listed for use over bathtubs and showers when connected to a GFCI-protected branch circuit.

# PERFORMANCE RATINGS – IN-LINE VENTILATORS IL40LA1151, IL50LA1151 & IL70LA1151

## AMCA LICENSED PERFORMANCE

		CFM / SONES - AT STATIC PRESSURES (Ps - inches of H <sub>2</sub> O)													
MODEL NO.	NOMINAL VOLTAGE		0.0" Ps	.10" Ps	.125" Ps	.250" Ps	.375" Ps	.50" Ps	.625" Ps	.750" Ps	.875" Ps	1.0" Ps	NOMINAL RPM	AMPS @ 60 Hz	WATTS
IL40LA1151	120 VAC	<b>CFM (S)</b>	450	415	406	360	313	271	223	167	90	6	775	1.4	146
		<b>SONES (S)</b>	1.4	1.6	1.6	1.9	2.2	2.6	2.9	3.4	3.6	3.9			
		<b>CFM (R)</b>	442	415	408	372	336	296	239	193	111	28	875	1.4	146
		<b>SONES (R)</b>	1.6	1.7	1.7	2.0	2.4	2.6	3.1	3.4	3.9	4.1			
IL50LA1151	120 VAC	<b>CFM (S)</b>	546	526	519	496	472	447	407	364	306	232	890	2.2	232
		<b>SONES (S)</b>	2.4	2.4	3.4	3.7	3.9	3.8	3.9	4.0	4.3	4.3			
		<b>CFM (R)</b>	528	516	513	494	470	446	415	389	334	247	990	2.2	232
		<b>SONES (R)</b>	2.9	3.8	3.4	3.7	3.5	3.6	3.9	4.0	4.2	4.4			
IL70LA1151	120 VAC	<b>CFM (S)</b>	704	686	681	656	631	604	575	533	480	412	1090	2.9	313
		<b>SONES (S)</b>	3.6	3.8	3.7	3.9	4.0	4.2	4.3	4.4	4.7	5.0			
		<b>CFM (R)</b>	680	667	663	644	621	594	557	513	440	342	1205	2.9	313
		<b>SONES (R)</b>	5.0	5.0	5.0	5.3	5.2	5.1	5.3	5.5	5.4	5.5			

(S) = Straight Through; (R) = Right Angle

Performance ratings include the effects of backdraft damper in the airstream. Speed (RPM) shown is nominal. Performance is based on actual speed of test. The sound ratings shown are loudness values in fan sones at 5' (1.5m) in a hemispherical free field calculated per AMCA Std. 301. Values shown are for Installation Type D: Ducted inlet, Ducted outlet. Ratings do not include the effect of duct end correction. Performance ratings include the effects of 18 feet of round inlet duct and, if needed, a rectangular to round duct transition in the airstream. Performance shown is for Installation Type D: Ducted inlet, Ducted outlet.

## WEIGHT

MODEL NO.	SHIPPING WT.
IL40LA1151	33.9 lbs.
IL50LA1151	33.9 lbs.
IL70LA1151	34.0 lbs.



AMERICAN COOLAIR CORP. / ILG INDUSTRY  
3604 MAYFLOWER ST.  
JACKSONVILLE, FLORIDA 32205  
TEL: 904-389-3646



"American Coolair Corp. / ILG Industry" certifies that the models shown herein are licensed to bear the AMCA Seal. The ratings shown are based on tests and procedures performed in accordance with AMCA Publication 211 (and AMCA Publication 311 if sound is also certified) and comply with the requirements of the AMCA Certified Ratings Program"



UL listed for use over bathtubs and showers when connected to a GFCI-protected branch circuit.