

# Installation Instructions for Type RE Recirculating Roof Ventilators

OPERATION AND MAINTENANCE INSTRUCTIONS—OTHER SIDE

## 1. Pre-Installation Check of Recirculating Roof Ventilators.

Before installation of an American Coolair Recirculating Roof Ventilator, a careful check should be made for shipping damage which may affect operation of the unit. Type RE Recirculating Roof Ventilators are shipped in three packages: the fan/damper plenum complete with fan/motor assembly and dampers; the curb cap or base assembly; and the wind shroud. Concealed damage to the wind shroud damper assembly and the base assembly is a possibility. If damage is found, file a claim immediately with delivering carrier. The fan/motor assembly is mounted in the fan/damper plenum. Check fan motor nameplate to be sure correct phase and voltage are being used. Before connecting motor to the power source, make sure the propeller turns freely without striking the fan frame or any foreign object. On belt drive units, pulley alignment and belt tension should be checked (see paragraph 2 under Operation and Maintenance). Check that the counter-balanced recirculating dampers mounted in the sides of the fan/damper plenum operate smoothly. If a diffuser is factory installed on the fan end of the fan/damper plenum check that the diffuser operates smoothly.

## 2. Installation Procedures.

a. **Installation of Fan/Damper Plenum Assembly.** The major component of the type RE Recirculating Roof Ventilator is the fan/damper plenum which contains the reversible fan, motor and dampers. The fan/damper plenum is shipped with the curb mounting angles turned to the inside for ease of shipping. The fan/damper plenum is the first component that must be installed. The fan/damper plenum can be mounted to the roof curb by either lowering through the roof curb from the roof or by raising from inside the building through the roof curb.

NOTE: Roof curb dimensions are critical. Carefully check inside and outside curb dimensions for proper fit and clearance. Curb size is different from standard PRV sizing.

If the unit is to be installed from the roof, unbolt the mounting angles from their shipping position and reattach as shown in Figure 2. If the fan/damper plenum came complete with factory mounted disconnect switch, it will be necessary to remove the switch before installing if the unit is to be installed from the roof, and to reattach it after the unit is supported by the roof curb. Holes in the mounting angles, that rest on the curb, are provided for securing the fan/damper plenum to the curb. Use flat headed hardware for attaching (not provided).

If the unit is to be installed from inside the building, leave the curb mounting angles attached in the shipping position or temporarily unbolt the angles until the top of the fan/damper plenum is raised through the roof curb far enough that the curb mounting angles can be attached to the fan/damper plenum as shown in Figure 2 and then lower the unit onto the roof curb and secure.

The fan/damper plenum for the type RE has recirculating dampers on opposite panels with an access door on one adjacent panel. When installing the fan/damper plenum make sure the orientation of the dampers are such that no building structures interfere with the operation of the dampers or restrict air flow to the dampers and that the access door is in a usable position.

b. **Installation of Base.** The base assembly is now installed over the curb mounting angles of the fan/damper plenum and the roof curb.

For installation of the base for the RE type unit refer to form

310-40 paragraph 2(a), copy attached. The base assembly does not include any fan components such as motor or blade assembly.

c. **Installation of the Wind Shroud Assembly.** For installation of the wind shroud to the base for the RE type unit refer to form 310-40 paragraphs 2(b), (c), and (d), copy attached.

d. **Wiring of the Fan Motor.** The fan in the type RE uses a reversible propeller to provide essentially equal air movement in either direction. When electrically wiring the fan motor make sure the fan blade rotation is correct to produce air flow in the required direction when electrical controls are energized. Proper reversing motor controls are necessary. Carefully check the two air flow/rotation labels on the fan for detail of proper operation.

**NOTE:** All local, state and federal codes should be checked to make sure all wiring, guarding and intended usage of the PRV unit(s) comply with all applicable codes. The proper type and class of PRV and motor should be used for air being handled such as explosive or other hazardous air mixtures.

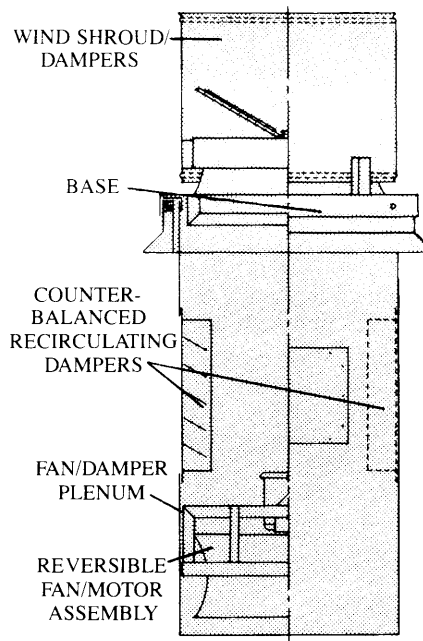

FIGURE 1  
Type RE Unit

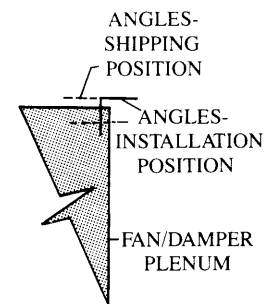

FIGURE 2  
Curb Mounting Angles

**AMERICAN**  
**Coolair**®

P.O. Box 2300 Jacksonville, Florida 32203  
Phone (904) 389-3646

# Operation and Maintenance Instructions for Type RE Recirculating Roof Ventilators

INSTALLATION INSTRUCTIONS—OTHER SIDE

**1. Cleaning and Adjustment.** The entire PRV should be cleaned as necessary to remove accumulated dust, dirt and other foreign matter which may collect on the blades or other parts. On belt drive models, belt(s) should be inspected and tension adjusted (see below). Belt alignment should also be checked to avoid excessive wear and premature failure. This same inspection of belt(s) and adjustment of tension should be made after first 8–10 hours of usage following installation. If rust or corrosion are found anywhere on the PRV, the affected area should be thoroughly cleaned and refinished.

**2. PRV Speed Adjustment.** All belt drive models are equipped with adjustable pitch motor pulley, the pitch setting made at the Factory operates the fan at the maximum safe load for the motor. Do not close pulley to increase fan speed as this will overload motor and cause damage to motor or trip-out. Pulley may be opened to reduce fan speed and thus decrease CFM. If pulley is opened to reduce fan speed, air velocity may be reduced below minimum essential for all-weather usage. If further information is required, contact your American Coolair representative.

**3. Belt Replacement and Tensioning (Belt drive models only).**

(a) Belt(s) should be inspected and tension adjusted at regular intervals. To replace belt(s), loosen motor bracket to release belt tension and drop old belt(s) off motor and fan pulleys. Do not roll new belt(s) over pulleys under tension. This practice can damage belts severely. Position new belt(s) on fan pulley and motor pulley. Adjust belt tension and retighten motor bracket bolts (see paragraph (b) below). Check belt alignment between motor pulley and fan pulley.

(b) To check belt tension, place a finger midway between fan pulley and motor pulley and push belt(s) inward about  $\frac{1}{2}$ " (at approximately 5 lb. force) for proper tension. To adjust tension, loosen motor bracket bolts and utilize Tension Adjustment Bolts to obtain correct belt tension. Retighten all motor bracket bolts to maintain correct tension. Recheck alignment of belts, motor pulley and fan pulley. **CAUTION:** Use of Tension Adjustment Bolts makes it easy to overtighten belts. When this occurs belts will soon fail. Do not overtension.

**4. Blade Pitch Adjustment (Both direct and belt drive).** The propeller has blades on which the pitch may be adjusted. The blade pitch is factory set for specified performance. As any change in blade pitch will affect motor load, contact your American Coolair representative for instructions before making any field adjustment of blade pitch. **DO NOT ATTEMPT TO CHANGE BLADE PITCH WITHOUT INSTRUCTIONS.**

**5. Lubrication.** On all belt drive models, fan bearings are factory lubricated for extended service. Pillow block type bearings are used. Relubrication annually or more

frequently is recommended depending on application. For best results use Shell Alvania No. 3 or equivalent. For lubrication of electric motor, see instructions supplied by motor manufacturer.

**6. Repair Parts.**

(a) **Belts**—Belts are standard V-belts used on industrial machines and replacements may be obtained through local industrial supply houses. If more than one belt is used on the fan, be sure to replace with matched sets. To install belts, see instructions above for belt replacement.

(b) **Blades**—If one or more blades on propeller are damaged, it is recommended that entire blade assembly be removed and returned to the Factory for necessary repair and rebalancing. Remove propeller from the motor or drive shaft.

(c) **Bearings**—Pillow block bearings may be replaced in the field.

(d) **Motor**—Motor repairs should be performed only by an authorized motor repair station. Contact the motor manufacturer or American Coolair for location of repair station.

**CAUTION:** Do not return damaged or defective parts to American Coolair without prior authorization. If repairs under warranty are claimed, see warranty terms in American Coolair catalog or contact the factory at Jacksonville, Florida. Claims for warranty repairs to electric motor should be made direct to the motor manufacturer.

WARNING	CAUTION
	<b>DO NOT</b> INSTALL FAN WITH MOVING PARTS WITHIN 8 FEET OF FLOOR OR GRADE LEVEL WITHOUT A GUARD THAT COMPLIES WITH OSHA REGULATIONS. <b>DO NOT</b> USE UNLESS ELECTRICAL WIRING COMPLIES WITH ALL APPLICABLE CODES. <b>DO NOT</b> WIRE WITHOUT PROVIDING FOR A POWER SOURCE DISCONNECT AT THE FAN ITSELF. <b>DO NOT</b> SERVICE EXCEPT BY A QUALIFIED MAINTENANCE TECHNICIAN AND ONLY AFTER DISCONNECTING THE POWER SOURCE. FAILURE TO OBSERVE THESE PRECAUTIONS CAN RESULT IN SERIOUS INJURY OR DEATH.

**AMERICAN**  
**Coolair**®

P.O. Box 2300 Jacksonville, Florida 32203  
Phone (904) 389-3646