

Exterior Mount Agricultural Building Ventilators



XM

Series

NBCXM54

NEFXM54

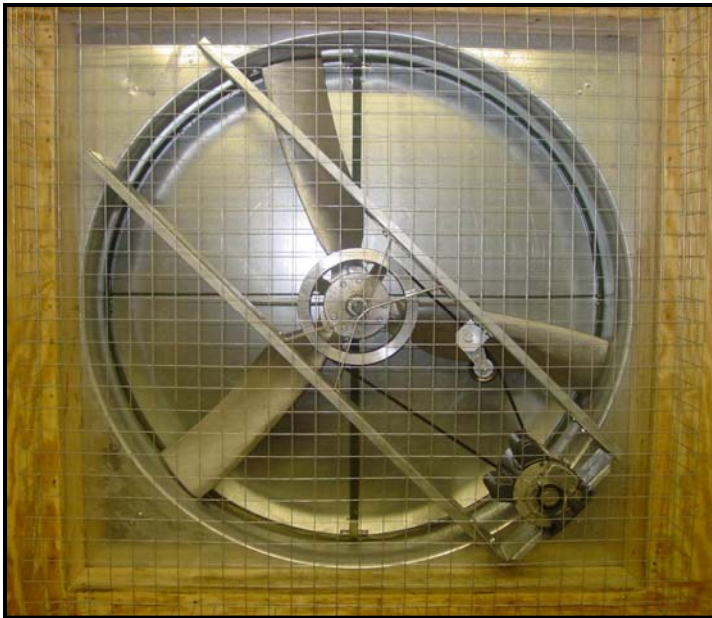

Proven durability and efficiency meet convenience and simplicity in American Coolair's **XM Series Exterior Mount Fans**. Engineered to mount directly to the outside of farm buildings, eliminating the need for a fan housing, the XM design saves on both material and assembly/installation costs.

Designed to be installed over a wall opening from 56 1/2" square to a maximum of 58" square, Coolair's NBC54XM or NEF54XM Damper Door fans are ideal for both new construction or replacing fans in existing buildings.

Whether using the economically efficient NEF formed steel blades, or Coolair's exclusive high efficiency cast aluminum airfoil NBC blades, XM Damper Door fans are engineered to maximize performance.

When the unit is energized, the doors fully open automatically, reducing blockage in the airstream to a minimum and optimizing airflow. When the unit is powered off, the doors automatically close and seal magnetically. Gasketing around the circumference of the doors provides a complete weather barrier.

All XM fan packages come complete with an automatic belt tensioner, and inlet & discharge guards.



Performance Ratings

The performance ratings listed below were obtained through testing by the Bioenvironmental and Structural Systems Lab (BESS Lab) at the University of Illinois. All fans were tested with a shutter and discharge guard, and some may also include an optional discharge cone as noted in the fan description. The fan was mounted flush to the test chamber face, as in an actual building installation. Power measurements were taken on the fan/motor combination and include motor efficiency and drive losses.



Cubic Feet per Minute (CFM) at Static Pressure														
Fan Model	Fan Size	BESS Lab Test #	Motor HP	Fan RPM @ .05"	0" S.P.		.05" S.P.		.10" S.P.		.15" S.P.		.20" S.P.	
					CFM	CFM/Watt	CFM	CFM/Watt	CFM	CFM/Watt	CFM	CFM/Watt	CFM	CFM/Watt
Exterior Mount NBC Fan with Discharge Cone & Guards														
NBCXM54L	54	14228	1	449	27,800	29.3	25,900	26.3	23,400	23.0	20,800	20.1	16,400	15.9
NBCXM54M		14229	1 1/2	515	31,700	22.5	29,900	20.4	28,000	18.6	25,900	16.9	23,400	15.1
NBCXM54L Δ		14231	1	445	27,400	28.6	25,300	25.4	23,100	22.6	20,400	19.6	15,600	15.1
NBCXM54M Δ		14230	1 1/2	524	32,100	24.1	30,500	22.2	28,500	20.0	26,600	18.3	24,200	16.5
Exterior Mount NEF Fan with Discharge Cone & Guards														
NEFXM54L	54	14235	1	446	26,400	31.9	24,700	27.8	22,700	24.1	19,900	19.8	16,400	15.7
NEFXM54M		14234	1 1/2	506	29,200	23.9	28,100	22.2	26,600	19.8	24,500	17.5	21,900	14.9
NEFXM54L Δ		14232	1	435	25,800	31.8	23,900	27.4	22,000	24.0	19,000	19.5	15,300	15.1
NEFXM54M Δ		14233	1 1/2	513	29,600	26.3	28,600	24.1	26,900	21.5	25,100	19.2	22,500	16.3

Δ – 3-Phase Units

Fan Dimensions

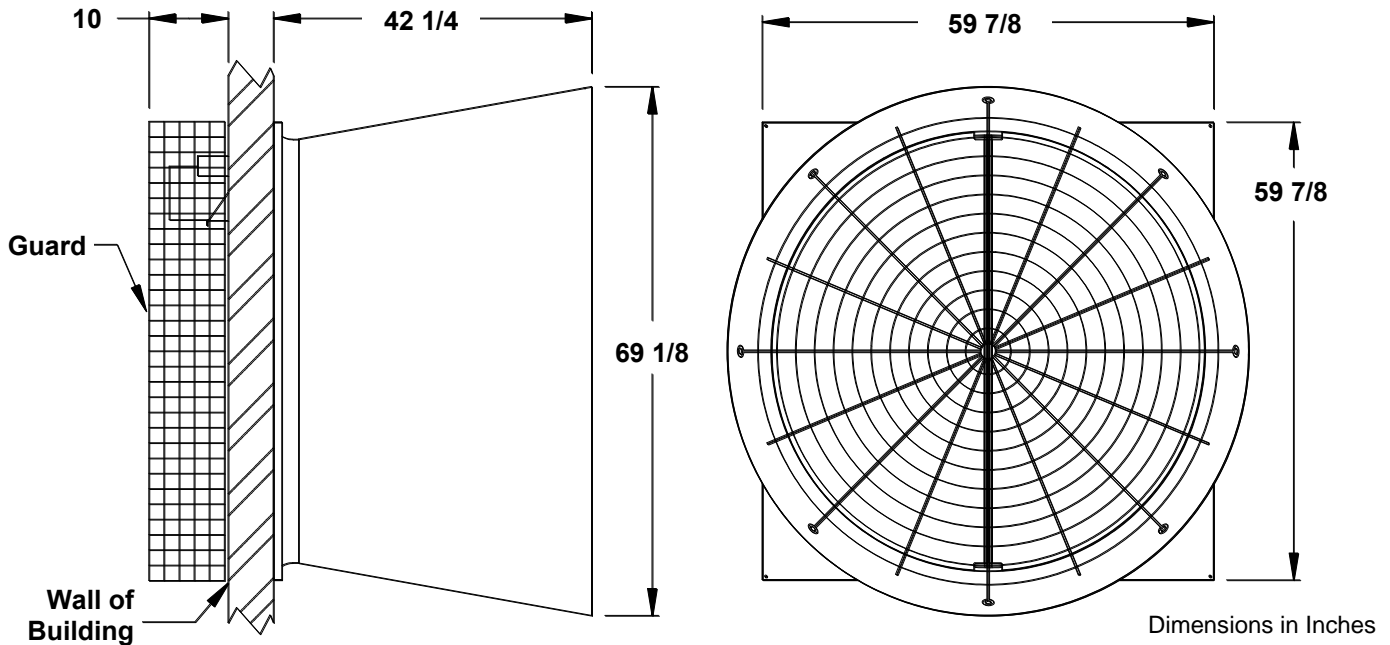

FARM PRODUCTS DIVISION
 P.O. Box 2300 Jacksonville, FL 32203
 PHONE – (904) 389-3646 FAX (904) 387-3449
 E-MAIL – agfans@coolair.com
 WEB – www.coolair.com